



Surface acoustic wave-based lab-on-a-chip for the fast detection of *Legionella pneumophila* in water

Mariacristina Gagliardi^{a,1}, Matteo Agostini^{b,1}, Francesco Lunardelli^c, Leonardo Lamanna^a, Alessio Miranda^a, Agostino Bazzichi^d, Antonella Giuliana Luminare^d, Fabrizio Cervelli^d, Francesca Gambineri^d, Michele Totaro^e, Michele Lai^e, Giuseppantonio Maisetta^e, Giovanna Batoni^e, Mauro Pistello^e, Marco Cecchini^{a,b,c,*}

^a NEST, Istituto Nanoscienze-CNR, Piazza San Silvestro, Pisa 56127 Italy

^b INTA S.r.l., Intelligent Acoustics Systems, Via Nino Pisano 14, Pisa I-56122 Italy

^c NEST, Scuola Normale Superiore, Piazza San Silvestro, Pisa 56127 Italy

^d ARCHA srl, via di Tegulaia, 10/A Ospedaletto, Pisa 56121, Italy

^e Department of Translational Research and New technologies in Medicine and Surgery, University of Pisa, Via S. Zeno 37, 56123 Pisa, Italy

ARTICLE INFO

Keywords:

SAW
Lab-on-chip
Legionella pneumophila
Detection
Acoustic sensor

ABSTRACT

Surface acoustic wave (SAW) -based immuno-biosensors are used for several applications, thanks to their versatility and faster response than conventional analytical methods. SAW immuno-biosensors can be usefully applied to promptly detect bacteria and prevent bacterial infections that can lead to severe diseases. Here, we present a SAW immuno-biosensor to detect *Legionella pneumophila* in water. Our device, working at ultra-high frequency (740 MHz), is functionalized with an anti-*L. pneumophila* antibody to maximize the specificity. We report the characteristic curve of the sensor, calculated measuring bacterial samples at known densities, and its related parameters. We also measure *L. pneumophila* samples contaminated with different Gram-positive and Gram-negative bacterial species (*Escherichia coli* and *Enterococcus faecium*) and samples diluted in mains waters. The proposed device is able to detect *L. pneumophila* in the range from $1 \cdot 10^6$ to $1 \cdot 10^8$ CFU/mL, with a limit of blank of $1.22 \cdot 10^6$ CFU/mL and a limit of detection of $2.01 \cdot 10^6$ CFU/mL. The nonspecific signal due to contaminant bacteria is very limited and measurements of *L. pneumophila* are not affected by contamination. We obtain a good detection also in mains water, representing a realistic matrix for *L. pneumophila*. Our results are encouraging and pave the way to the use of fast, easy-to-use, reliable and precise sensors to prevent bacterial infections in human activities.

1. Introduction

SAW-based sensors are sensitive and fast-responsive tools to be used for mass detection [1]. To date, acoustic transducers are involved in the manufacturing of several kinds of sensors based on SAWs, like Rayleigh surface acoustic wave (R-SAW), shear-horizontal surface acoustic wave (SH-SAW), Love wave (L-SAW), and several other devices [2]. In a typical biosensor, a biologically active molecule (probe) decorates the surface of the sensing element exposed to the sample, and interacts with the analyte [3]. Biosensors functionalized with antibodies or antigens are referred to as immuno-biosensors [4]. Thanks to their good performance, SAW immuno-biosensors find a variety of applications, e.g. in

the detection of proteins [5–8], viruses [9–14] and bacteria [15–19]. Bacterial pollution is a common environmental matter. The presence of pathogenic bacteria in the environment is directly related to a wide range of diseases [20]. Transmission of bacterial infections to humans occurs through water, air, food, or animals. Common route of transmission of bacterial infection are: airborne, waterborne, aerosol/droplet, contact [21]. Bacteria of the genus *Legionella* are pathogens that can cause legionellosis in humans. Legionellosis is a respiratory disease that includes fatal pneumonia called Legionnaires Disease (LD) and a minor disease called Pontiac Fever [22]. *Legionella* colonizes human freshwater environments, like air conditioning ducts [23], mains waters [24] and spa equipment [25]. Legionellosis mainly spreads from

* Corresponding author at: NEST, Istituto Nanoscienze-CNR, Piazza San Silvestro, Pisa 56127, Italy.

E-mail address: marco.cecchini@nano.cnr.it (M. Cecchini).

¹ These authors contributed equally.

such water sources, while the person-to-person transmission rarely occurs [26]. The estimated threshold value for this bacterium to present a health risk to humans is $1 \cdot 10^4$ - $1 \cdot 10^5$ CFU/L [27].

The ISO 11731:2017 standard furnishes the guideline for the enumeration of *Legionella* in potable, industrial, waste and natural waters [28]. The ISO enumeration technique is based on defined culture methods for the isolation and the estimation of bacteria. Culture methods present some limitations, related to the presence of non-cultivable variants [29,30], that are potentially pathogenic [31]. Moreover, the laboratory procedures are rather long, and can take up to 10 days [32]. Alternative techniques for monitoring *Legionella* already exist [33], like quantitative polymerase chain reaction (qPCR) [34] and immuno-based assays (ELISA) with a more rapid feedback time (about one day) [18]. However, despite their precision, those techniques have drawbacks such as the necessity of expert operators and expensive and time-consuming procedures. Diagnostic tools to identify *Legionella* in the shortest possible time and by nonspecialized operators definitely limits bacterial spread and the diffusion of related diseases. Large efforts should be done to reach this goal while maintaining sensor specificity and sensitivity. To date, the literature reports a limited number of optical, electrochemical or immuno-biosensors for the quantification of *Legionella pneumophila* in Lab-on-Chip [35–37]. Among the SAW-based sensors, the literature reports a Love wave-based device for the detection of *Legionella* and *E. coli*, analyzing different functionalization protocols [38]. In the cited work, *Legionella* densities analyzed were comprised in the range from $7.5 \cdot 10^8$ to $2.5 \cdot 10^6$ cells/mL.

The present work proposes a SAW device working at ultra-high frequency (around 740 MHz), functionalized with an anti-*L. pneumophila* antibody. We have tested the device with a wide range of *L. pneumophila* suspensions, from $1 \cdot 10^2$ to $1 \cdot 10^8$ CFU/mL and calculated the limit of detection and the limit of blank. Moreover, we have tested suspensions

of bacteria containing common water contaminants i.e. *Escherichia coli* and *Enterococcus faecium*, and a mix of *Legionella* and *E. coli/E. faecium*, to evaluate sensor specificity. The same sensor was tested with samples from mains water, both clean and contaminated with *L. pneumophila*, in order to mimic environmental-like conditions.

2. Materials and methods

Reagents and solvents are purchased from Sigma Aldrich, if not otherwise stated.

2.1. Surface acoustic wave Lab-on-a-Chip fabrication

Each SAW device (Fig. 1a) used in this study is fabricated on a $1 \text{ cm} \times 1 \text{ cm}$ lithium niobate (LN) 128° YX substrate (Nano Quartz Wafer, Langenzenn, Germany). The SAW structures are constituted by interdigitated transducer (IDT) electrodes patterned on the LN substrate previously covered with Ti/Au layer and they consist of seven 1-port SAW resonators working in the ultra-high-frequency (UHF) regime (around 740 MHz) act as the sensors. One of the sensors, isolated from the other, is used as reference. In the center of the structure a larger IDT operating at 100 MHz acts as a mixer (Fig. 1b and c).

The Ti/Au metallization (10/100 nm) is obtained by thermal evaporation, the design of the structures is patterned on a layer of resist ma-N 1407 (Microresist Technology) by the laser writing process (mL-3, Durham Magneto Optics, Caxton, United Kingdom, UV dose 31.6 mJ/cm^2) and then transferred to the metal film by reactive-ion-etching (RIE, Sistec, Ar at 0.9 mbar, 50 W, 17 min). The residual Ti layer is then etched by a piranha solution ($\text{H}_2\text{SO}_4:\text{H}_2\text{O}_2$ 3:1 v/v, 2 min) leaving the Ti/Au only in where the IDTs and necessary contacts are needed.

Before microfluidic measurements, the devices are sealed by a

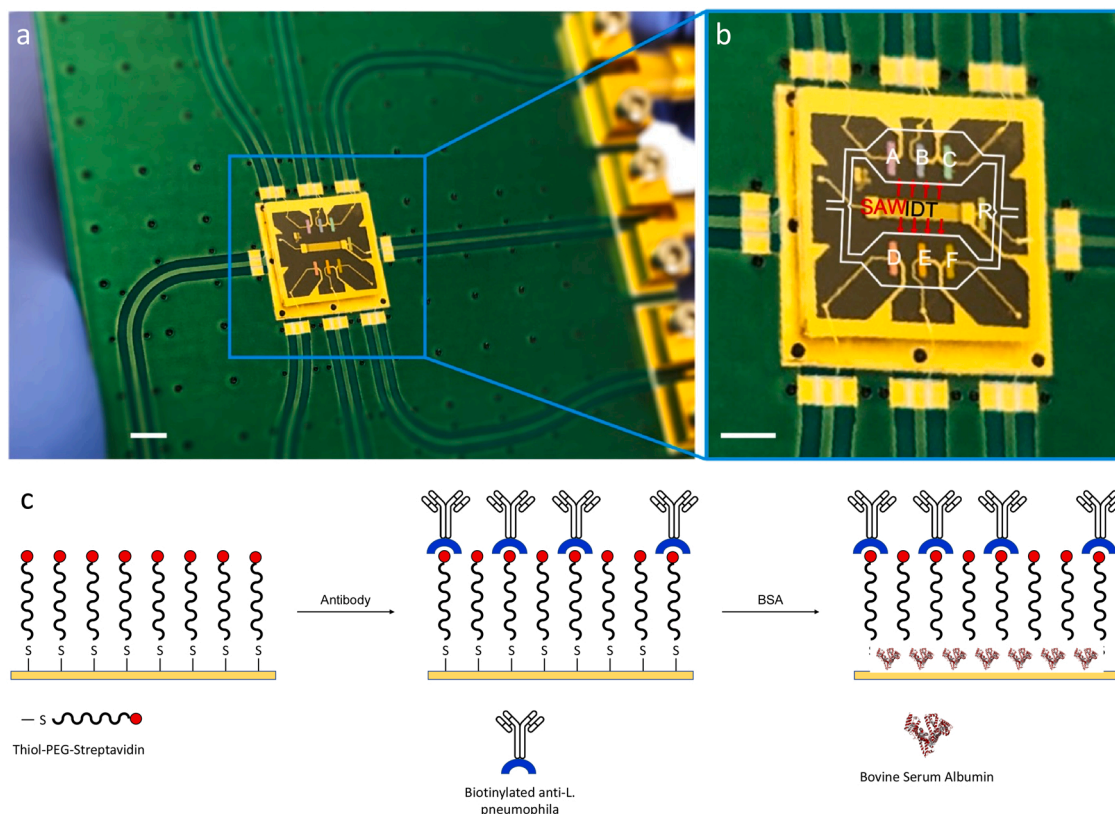

Fig. 1. The SAW-LoC device: a the chip mounted on the printed circuit board; b chip magnification showing sensors, indicated with uppercase letters, the sensor R used as reference, and the interdigital transducer IDT that generates the SAWs moving in the directions indicated by the red arrows. White traces schematize the fluidic microchannels; scale bars = 0.3 mm. For further detail on Lab-on-Chip architecture, refer to [14]; c schematization of sensor functionalization (not in scale): formation of the PEG adlayer, functionalization with the anti-*Legionella* antibody, and blocking with BSA.

microfluidic chamber and a glass coverslip. The microfluidic chamber is made of Polydimethylsiloxane (PDMS, Sylgard® 184, 10:1) and its microchannels are patterned by curing it on a SU8–2100 (Microresist Technology) mold. The microfluidic chamber presents two fluidic ports (inlet/outlet) connected to two incubation microchambers covering the sensing resonators, and two isolated air-filled microchambers above the IDTs and the reference resonator. Inlets, outlets, and two bubble traps in the microchannels are made using a biopsy puncher. The PDMS microchannel is fixed by a clamp to the chip.

2.2. Lab-on-a-chip radio frequency characterization and operation

The device is wire-bonded on a printed circuit board (PCB) and connected to the radiofrequency (RF) instrumentation. The midmost IDT, which is used as a mixer, is powered by a single tone RF signal at 99.7 MHz from a vector signal generator (N5181A MXG, Agilent Technologies) followed by an RF amplifier (ZHL-5 W-1, Mini-Circuits) to have an on-chip power is 22 dBm. A vectorial network analyzer (VNA, E5071C, Agilent Technologies) connected to an RF switch (34980A, Agilent Technologies) allows measuring the reflected power spectrum (S11) of the single resonators at a central frequency of around 740 MHz with a span of 40 MHz at 15001 points. An in-house software based on LabView® is used to pilot the RF-switch and the VNA. The mechanical characterization of the device was performed with a laser doppler vibrometer (LDV, UFH-120, Polytec).

2.3. Surface functionalizations of biosensors

Functionalizations are obtained by placing droplets (2 µl) of used solutions for each step on the resonator surface. During functionalization, the devices are maintained under a water-saturated atmosphere to prevent evaporation phenomena. Surface functionalization of the sensors consists in three steps (Fig. 1c): i. formation of an adlayer serving as a linker for the probe molecule and with antifouling properties; ii. conjugation of the probe molecule onto the adlayer; iii. blockage of the remaining non-specific binding sites. More in detail, the adlayer is obtained with a solution of heterobifunctional thiol-polyethyleneglycol-streptavidin (PEG-STREP, PEG block Mw 2 kDa, NANOCS Inc.), 1 mg/mL, in water (incubation time: 90 min); probe binding is obtained with a solution of biotinylated anti-*Legionella Pneumophila* antibody (anti-*L. pneumophila*, Abcam, ab20527), 500 µg/mL in phosphate buffer saline (PBS, 90 min); the blockage of residual nonfunctionalized sensor surface is obtained by a solution of bovine serum albumin (BSA), 1 mg/mL in PBS (15 min). At the end of each step, the devices are rinsed with water by dipping into a beaker filled with deionized water, and gently dried under nitrogen flux.

2.4. Bacteria cultivation and preparation for ELISA assay

L. pneumophila strains were isolated from sanitary water and genotyped at the Hygiene Laboratory of the University of Pisa as previously described [39]. *L. pneumophila* strains were cultured on Buffered Charcoal Yeast Extract (BCYE) agar at 37 °C in CO₂-enriched atmosphere for 7–10 days. Bacterial colonies of each strain of *L. pneumophila* were diluted in PBS to obtain suspensions with OD₆₀₀ of 0.1 (corresponding approximately to 1·10⁸ CFU/mL). After two washes with PBS, bacterial cells were inactivated by incubation in 4 % paraformaldehyde for 30 min at room temperature, for safety reasons. After two washes with PBS, bacteria were suspended in PBS to obtain a density (OD₆₀₀) of 0.3 and 0.03 corresponding to 3·10⁸ and 3·10⁷ CFU/mL, respectively. Before detection by the sensor, inactivated suspensions of *L. pneumophila* ATCC 33152 were sonicated at 45 kHz for 60 min in an ultrasonic bath sonicator (VWR, Ultrasonic cleaner), in order to disrupt bacterial aggregates.

The following bacterial strains, *Escherichia coli* ATCC 25923, *Pseudomonas aeruginosa* ATCC 27853, *Staphylococcus epidermidis* ATCC 35984 and *Enterococcus faecium* 48840 were used as negative control in

ELISA assays and in sensor detection. Such bacterial strains were cultured in LB broth (Sigma) at 37 °C in agitation for 20 h and then diluted in PBS up to a density (OD₆₀₀) of 0.3 and 0.03, respectively.

2.5. Enzyme-linked immunosorbent assay (ELISA)

A volume of 30 µl of each bacterial suspension, containing approximately 10⁶ or 10⁷ bacterial cells was distributed in wells of 96 well plates and incubated for 20 h at 37 °C in static conditions to obtain the coating of wells. After three washes with PBS containing 0.05 % Tween 20 (washing solution), the plates were blocked with PBS containing 5 % (v/v) BSA (3 h, 37 °C). After three washes with the washing solution, the samples were incubated with 100 µl of anti-*Legionella pneumophila* polyclonal antibody Abcam 20527 (Ab20527) diluted 1: 2500 in antibody buffer (0.05 % Tween 20 with 3 % BSA) (2 h, 37 °C). After removing the unbound primary antibody by three washes with the washing solution, a volume of 100 µl of goat anti-rabbit IgG peroxidase conjugate (Sigma), diluted 1:10.000 in antibody buffer was added (1 h, 37 °C). After three more washes, 100 µl per well of substrate, consisting of 3,3',5,5'-Tetramethylbenzidine 50 µg/mL (Sigma) and 30 % hydrogen peroxide (1µl/mL) in 0.1 M citrate-phosphate buffer, pH 5.0, was added. The reaction was stopped by the addition of 100 µl per well of 2 M sulfuric acid. Absorbance at 450 nm was determined with a plate reader (Fisher Scientific). The following controls were run in parallel: i) wells incubated with antibody buffer without bacteria; ii) wells with antibody buffer instead of primary antibody.

2.6. Sample detection

Inactivated and sonicated *L. pneumophila* ATCC 33152 samples, obtained as described before, are serially diluted in physiological solution to obtain bacterial suspension with density ranging from 1·10⁸ to 1·10² CFU/mL, and added with 4 % v/v of performic acid, before injecting them in the fluidic chambers (4.5 µl). All the samples are incubated for 60 min in stop-flow conditions. Measures are performed with and without SAW during incubation with bacteria.

As a negative control, a mix solution of *E. coli* ATCC 25923 and *Enterococcus faecium* 48840 is measured in sensors functionalized with the anti-*L. pneumophila* antibody. The concentration of each bacterial strain in the mix is 8·10⁶ CFU/mL. The sensor specificity is evaluated measuring a mix of *L. pneumophila* ATCC 33152, *E. coli* ATCC 25923 and *Enterococcus faecium* 48840. The concentration of each bacterial strain in the mix is 8·10⁶ CFU/mL. Surface sensors at the end of the experiments are analyzed by optical microscopy.

We also test our device in a blind control procedure. The blind procedure consists in the measure of two samples, one containing *Legionella* and one clean, diluted in mains water.

At the end of sample incubation, sensors are rinsed with deionized water and dried under nitrogen flux.

2.7. Data analysis

We acquire at least five spectra for each resonator before and after the sample detection. The resonance frequency shift of each resonator is calculated by using an algorithm based on the cross-correlation among the spectra. The final frequency shift from the sample analysis with the SAW device is calculated as the average and the standard error of the signal from the six biosensors before the sample injection and after the rinsing, corrected by subtracting the signal from the reference sensor. The statistical analysis of data obtained in control experiments and in the blind tests are performed with a t-test algorithm. In boxplots, the box indicates the data range from the first to the third quartile, the inner line through the box is the median value, and the whiskers delimitate the overall data range. Through the text, reported data are mean values and related standard errors.

Experimental data obtained from the analysis of *L. pneumophila*

samples at different concentrations are fitted with a Langmuir-line model described by (Eq. 1):

$$f(c) = a + \frac{b}{1 + \left(\frac{1}{K \cdot c}\right)^n} \quad (1)$$

In this equation, f is the function to be fitted, a and b are fitting parameters, c is the bacterial concentration in the sample solution, K is the association constant, and n is the heterogeneity index related to bindings occurring on heterogeneous surfaces. The values for the K and n from data fitting are calculated in the following cases: case A) measured signal as a function of the sample solution concentration, case B) measured signal as a function of the effective amounts of bacteria injected in the sensor chamber, and case C) measured signal as a function of the number of bacteria counted on the chip surface after incubation. The Langmuir-like proposed model is also used for the calculation of the biosensor Limit of Blank (LoB) and the Limit of Detection (LoD).

3. Results and discussion

We first tested the ability of the anti-*L. pneumophila* polyclonal antibody Ab20527 to detect different *L. pneumophila* strains inactivated with paraformaldehyde (three environmental and one ATCC strains belonging to serogroup 1, and three environmental strains belonging to serogroup 2–14) by ELISA assay. Ab20527 detected all the strains tested of *L. pneumophila* serogroup 1 (Sg1) in a dose-dependent manner at both bacterial loads (10^6 and 10^7 CFU/well), whereas it detected *L. pneumophila* Sg2–14 only at the highest bacterial load (10^7 CFU/well) (Fig. 1). The higher affinity of Ab20527 to Sg1 than Sg2–14 of *L. pneumophila* is possibly due to the production procedure, as Ab20527 was produced by rabbit immunization with *L. pneumophila* ATCC 33152 strain, which belongs to Sg1. The high affinity of Ab20527 towards Sg1 is crucial as such serogroup of *L. pneumophila* causes about 85 % of all legionellosis cases in Europe [40]. Moreover, such antibody showed high specificity for *L. pneumophila* as other Gram-positive (*S. epidermidis* and *E. faecium*) and Gram-negative (*E. coli* and *P. aeruginosa*) bacterial species tested were detected at very low levels (Fig. 2).

Our device is expected to exhibit a red shift of the resonance frequency due to the mass adhesion on the gold fingers [41,42]. The signals obtained from measures are in line with this expectation.

The first measure is performed to evaluate the surface functionalization. Starting from the free surface condition (acquired signal: 0 ± 3 kHz), we register an average frequency shift after the sensor functionalization of -139 ± 4 kHz. The negative frequency shift confirms the mass adhesion and thus the functionalization.

The experimental dataset of *L. pneumophila* detection (Fig. 3a) is generated from 16 individual immuno-biosensors without SAW during the sample incubation. Using the value of frequency shift registered before functionalization as baseline, the resonance frequency shift for the samples at different concentrations is in the range from -192 kHz to -527 kHz. Data follow a typical trend identifying the characteristic curve of the sensor. Frequency shifts measured for samples with concentration lower than $1 \cdot 10^4$ CFU/mL are out of the working range of the sensor. In measures with SAW on during sample incubation signals are null (data not shown). Unlike the detection of viruses [14], bacteria seem not to adhere with the mechanical streaming of the sample.

Control measures (Fig. 3b) obtained with the bacterial mix composed of *E. coli* and *E. faecium* (negative control) give an average net frequency shift (-12 kHz \pm 7 kHz) around 7 times lower with respect to the samples containing the bacterial mix composed of *L. pneumophila*, *E. coli* and *E. faecium* (-78 kHz \pm 8 kHz). The net shift is calculated considering the frequency shift after functionalization as baseline. Different signals result in a statistically significant difference with $p = 0.002$. It indicates that the nonspecific signal due to contaminant bacteria does not affect the measure. Moreover, the high specific signal obtained from measures of the mix of three bacteria indicates that the sensor still has high specificity also in the presence of other bacterial contaminants. A direct comparison of results with those summarized in Fig. 3a is obtained considering the functionalization shift as baseline. The mean value measured for the sample containing *L. pneumophila* is -217 kHz, which is quite in line with results obtained with samples non contaminated with different bacteria.

Blind measures obtained with samples diluted in mains water (Fig. 3c), without (negative control) and with added *L. pneumophila* (positive control), provide net shifts of 4 kHz \pm 2 kHz and -70 kHz \pm 16 kHz respectively, with a statistical significance of $p = 0.028$. The measure confirms the capability of the sensor to give statistically different signals in a blind procedure. With this measure, we also demonstrate that the sensor works well also with a realistic matrix for

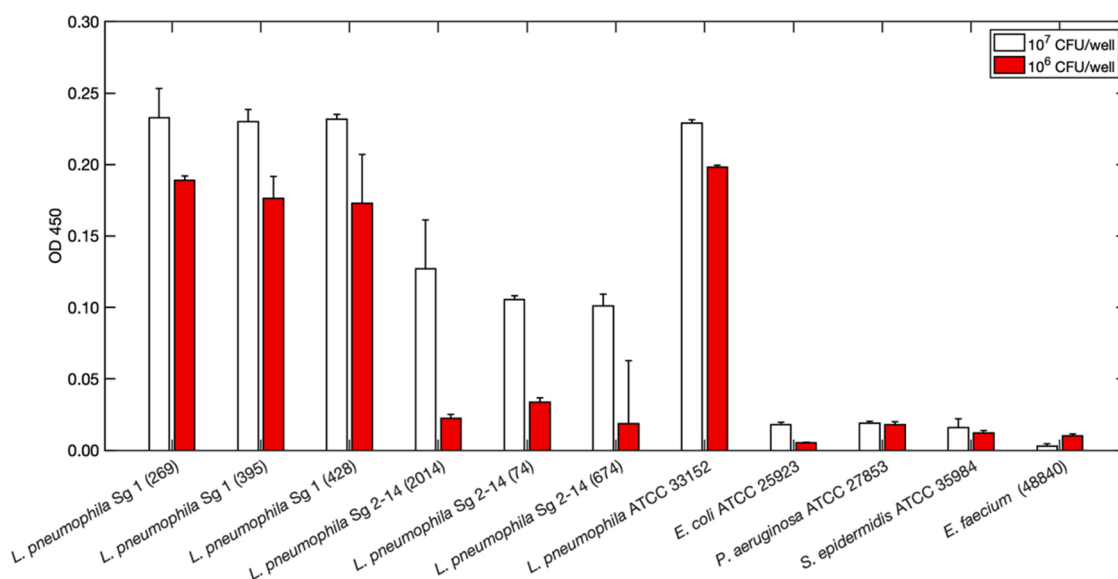

Fig. 2. Detection of inactivated *Legionella pneumophila* strains by ELISA assay using the polyclonal antibody Ab20527. To validate such antibody for *Legionella pneumophila* detection, four bacterial strains belonging to Sg1 and three strains to Sg 2–14 were used. *L. pneumophila* ATCC 33152 was used as positive control whereas two Gram-negative bacteria (*E. coli* ATCC 25923 and *P. aeruginosa* 27853) and two Gram-positive bacteria (*S. epidermidis* ATCC 35984 and *E. faecium* 48840) were tested as negative controls.

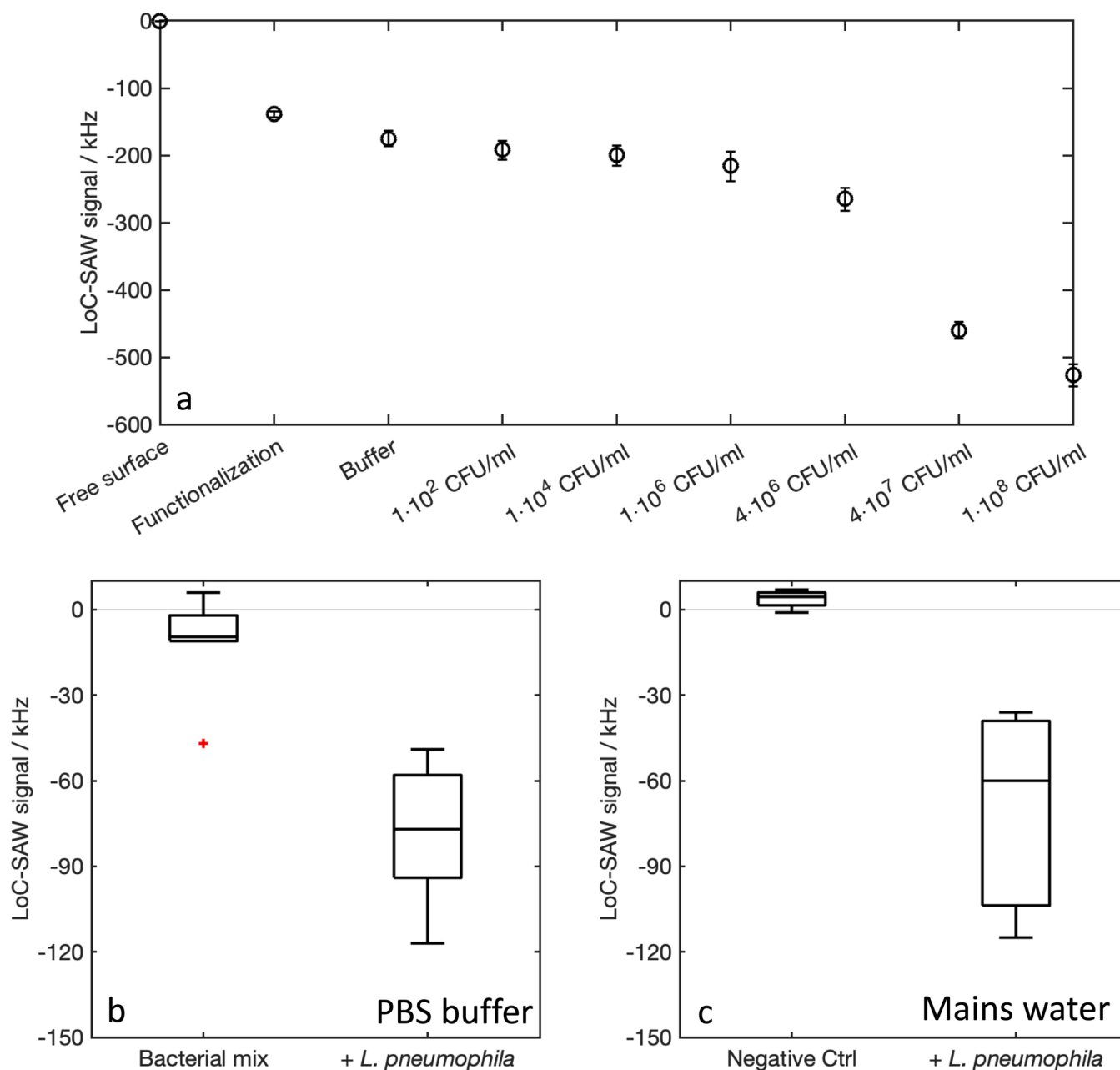

Fig. 3. Results of LoC-SAW device: a overall dataset obtained from the measures on different concentration *L. pneumophila* samples (overall number of sensors $n = 16$); b control experiments with bacterial mix: *E. coli* and *E. faecium* with concentration of $8e^6$ CFU/mL per each bacterial strain (negative control, $n = 6$), mix of *L. pneumophila*, *E. coli* and *E. faecium* with concentration of $8e^6$ CFU/mL per each bacterial strain (positive control, $n = 8$); c blind measure with samples diluted in mains waters: empty sample (negative control, $n = 4$) and sample added with *L. pneumophila* (positive control, $n = 5$).

L. pneumophila, or mains waters. The mean frequency shift calculated on the baseline acquired before functionalization is -209 kHz, which is in line with data obtained in experiments with clean *L. pneumophila* samples.

Optical imaging allows evaluating and quantifying the number of bacteria bound to the sensor surface after the detection (pictures not shown). Bacterial count visibly increases with the exposure of the biosensor at higher concentrations of *L. pneumophila* in sensors used for measurements summarized in Fig. 3a. Bacteria distribution over the surface is homogeneous, in particular in sensors used to measure samples with higher concentrations. Bacterial count in sensors used to measure the overall *L. pneumophila* dataset linearly increases by increasing sample concentration (Fig. 4a), indicating that saturation does not occur in the analyzed concentration range.

Optical images of sensors used for control measures clearly indicate a different count in sensors incubated with the negative control mix and the positive control mix (Fig. 4b-c). In the negative control, the count is close to zero and the overall sensor surface results clean. On the other hand, in the sensor incubated with the positive control the count is visibly higher and in line with optical images obtained for clean samples.

Langmuir-like fittings (Fig. 5) are obtained for all the three analyzed cases. Such proposed modelling is used to calculate K , n , LoB and LoD (Table 1). Calculated parameters K and n are related to a solid-liquid equilibrium only in cases A and B, while for case C such parameters are calculated after the measure, when all the bacterium/antibody interactions are already stable.

The proposed model highlights the strong dependence of the sensor signal on the actual adhered bacteria. Indeed, in the plot of LoC-SAW

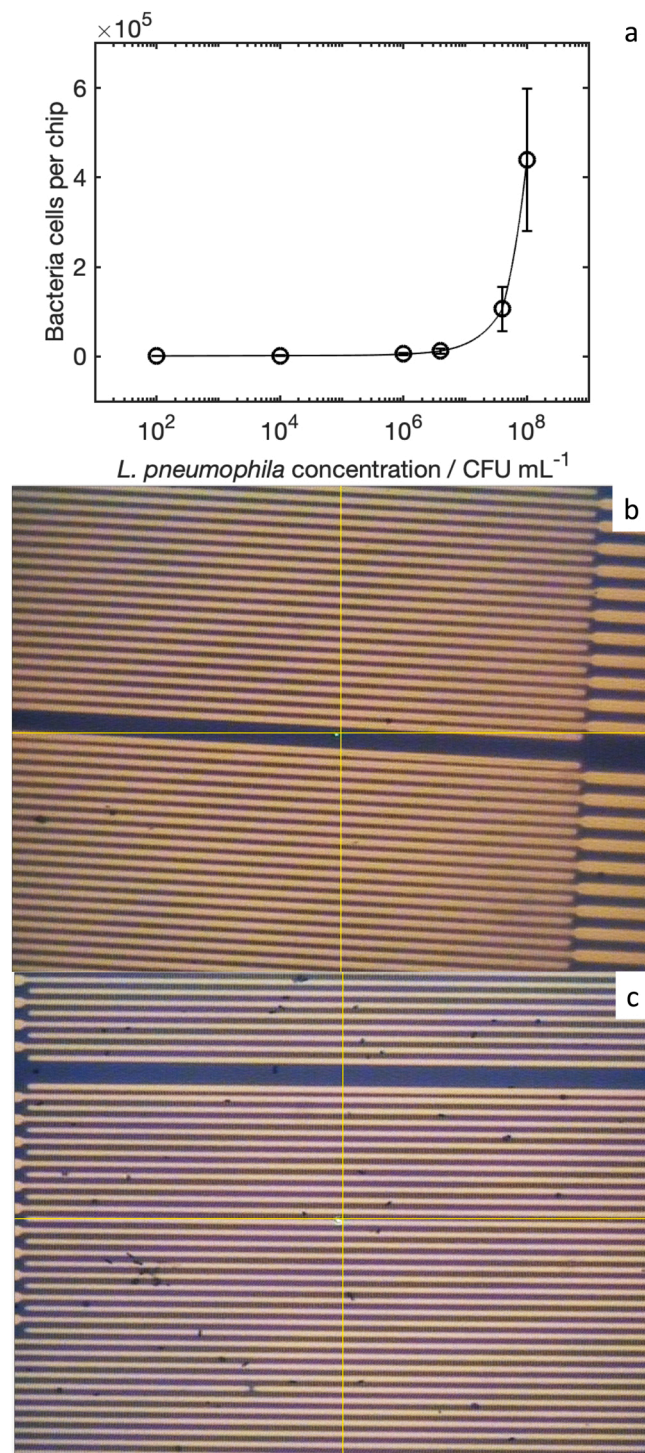

Fig. 4. Optical imaging of sensor surfaces after sample detection: a bacteria count in sensors used to analyze the overall *L. pneumophila* dataset. b *E. coli* and *E. faecium* with concentration of $8 \cdot 10^6$ CFU/mL per each bacterial strain (negative control); c Mix of *L. pneumophila*, *E. coli* and *E. faecium* with concentration of $8 \cdot 10^6$ CFU/mL per each bacterial strain (positive control); in microscopies, magnification is 100x.

signal vs. bacterial concentration in the sample the signal seems to be not dependent on concentration at values lower than $1 \cdot 10^6$ CFU/mL. On the contrary, a clear dependence on the counted bacterial cells on the sensor surface after the measure is shown.

The value of K in case A is three orders of magnitude lower than that calculated in case B. This parameter is related to the equilibrium

between bacteria and probe molecules, and lower values indicated weaker interactions. In this case it is not possible to directly compare the two values, due to the different calculation provided, but it can be assumed that the LoC SAW signal is more related to the number of bacterial CFUs on the sensor surface than to the sample concentration. On the other hand, values of K are similar for cases B and C, confirming that the strong interactions in the liquid phase are due to the adhesion of bacteria to the sensor surface.

Values of n are in all cases close to one, indicating a homogeneous adhesion of bacteria over the surface and, thus, a homogeneous distribution of the probe.

The calculated LoD is in line with that postulated in [38] for a similar SAW immuno-biosensor for *Legionella* detection. The LoD calculated over the actual number of bacteria adhered over the sensor surface is significantly lower, indicating the high potential of the proposed sensor to detect very low amounts of bacterial cells.

While obtained detections are reliable, the calculated LoD (case A) is too high to identify a potentially harmful contamination, considering the limit of $1 \cdot 10^4$ – $1 \cdot 10^5$ CFU/L [27]. This aspect can be easily overcome by concentrating the sample to measure, which is an already established procedure in the measure of *Legionella* bacteria [43].

4. Conclusion

The proposed immuno-biosensor has demonstrated good capability to measure inactivated *L. pneumophila* bacteria in aqueous samples. The characteristic curve of the device indicates a working range of sample concentration from $1 \cdot 10^6$ CFU/mL to $1 \cdot 10^8$ CFU/mL, which is state-of-the-art for SAW device bacteria biosensors. The same device shows a very limited nonspecific signal, measured with samples containing contaminant bacteria. Moreover, we successfully measured *L. pneumophila* also in contaminated samples, demonstrating the high specificity of the sensor. We positively tested our device with mains waters, which is a realistic matrix for *L. pneumophila*.

With this work we have demonstrated the feasibility of *L. pneumophila* detection by means of a SAW LoC device working at ultra-high frequency regime. As a future development, we will apply the same technology to the detection of different bacteria, in order to provide a tool for the rapid detection of bacterial contamination in human buildings.

CRedit authorship contribution statement

Mariacristina Gagliardi: Methodology, Formal analysis, Investigation, Writing – original draft, Writing – review & editing, Visualization. **Matteo Agostini:** Conceptualization, Formal analysis, Investigation, Writing – review & editing. **Francesco Lunardelli:** Formal analysis, Investigation, Writing – review & editing. **Leonardo Lamanna:** Investigation, Writing – review & editing. **Alessio Miranda:** Investigation, Writing – review & editing. **Agostino Bazzichi:** Investigation, Writing – review & editing. **Antonella Giuliana Luminare:** Methodology, Investigation, Writing – review & editing. **Fabrizio Cervelli:** Investigation, Writing – review & editing. **Francesca Gambineri:** Resources, Writing – review & editing, Funding acquisition. **Michele Totaro:** Investigation, Writing – review & editing. **Michele Lai:** Methodology, Writing – review & editing. **Giuseppantonio Maisetta:** Conceptualization, Formal analysis, Investigation, Resources, Writing – review & editing. **Giovanna Batoni:** Conceptualization, Formal analysis, Investigation, Resources, Writing – review & editing. **Mauro Pistello:** Resources, Writing – review & editing, Funding acquisition. **Marco Cecchini:** Conceptualization, Formal analysis, Resources, Writing – review & editing, Visualization, Supervision, Funding acquisition.

Declaration of Competing Interest

The authors declare the following financial interests/personal

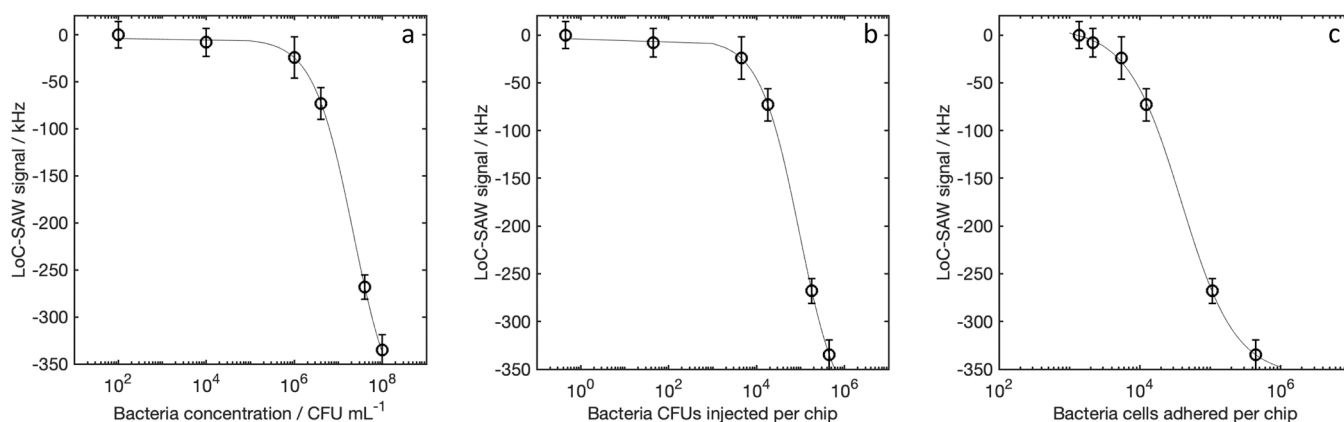

Fig. 5. Langmuir-like fitting of experimental data as a function of: a *L. pneumophila* concentration in the injected sample solution, b *L. pneumophila* cells injected in the sensor chamber in the sample volume (4.5 μ l), c Adhered *L. pneumophila* cells counted on the chip surface after the detection.

Table 1

Fitting parameters and standard errors (SE) for the Langmuir model K and n, and related values of LoB and LoD calculated from experimental data; data are elaborated for the following cases: A) measured signal as a function of the sample solution concentration ($R^2 = 0.9996$), B) measured signal as a function of the effective amounts of bacteria injected in the sensor chamber ($R^2 = 0.9997$), and C) measured signal as a function of the number of bacteria counted on the chip surface after incubation ($R^2 = 0.9997$).

Case	K (SE)	n (SE)	LoB	LoD
A	$4.64 \cdot 10^{-8}$ ($8.10 \cdot 10^{-9}$) (CFU/mL) ⁿ	0.96 (0.06)	$1.22 \cdot 10^6$ (CFU/ mL)	$2.01 \cdot 10^6$ (CFU/ mL)
B	$1.84 \cdot 10^{-5}$ ($1.39 \cdot 10^{-6}$) (CFU) ⁿ	0.96 (0.05)	$5.51 \cdot 10^3$ (CFU/ chip)	$9.06 \cdot 10^3$ (CFU/ chip)
C	$2.58 \cdot 10^{-5}$ ($1.76 \cdot 10^{-6}$) (cells) ⁿ	1.13 (0.06)	$4.97 \cdot 10^2$ (cells/ chip)	$8.17 \cdot 10^2$ (cells/ chip)

relationships which may be considered as potential competing interests: Marco Cecchini reports financial support was provided by Tuscany Region. Francesca Gambineri reports financial support was provided by Tuscany Region. Mauro Pistello reports financial support was provided by Tuscany Region.

Data availability

Complete raw and processed datasets are available in: Gagliardi, Mariacristina et al. (2023), Data from: Surface Acoustic Wave-based Lab-On-a-Chip for the fast detection of Legionella pneumophila in water, Dryad, Dataset, <https://doi.org/10.5061/dryad.0gb5mkm53>.

Acknowledgements

This work was co-funded by Regione Toscana – BANDO FAR-FAS 2014 – CUP CIPE: D51B18000750009; CUP SVILUPPO TOSCANA: 4421.02102014.072000081, with the project “SENSOR – Novel Real Time Sensors for the Detection of Microbiological and Chemical Contamination in Environmental and Biomedical Matrices”.

References

- Y. Huang, P.K. Das, V.R. Bhethanabotla, Surface acoustic waves in biosensing applications, *Sens. Actuators Rep.* 3 (2021), 100041, <https://doi.org/10.1016/j.snr.2021.100041>.
- D. Mandal, S. Banerjee, Surface acoustic wave (SAW) sensors: physics, materials, and applications, *Sensors* 22 (2022), <https://doi.org/10.3390/s22030820>.
- V. Naresh, N. Lee, A review on biosensors and recent development of nanostructured materials-enabled biosensors, *Sensors* 21 (2021), <https://doi.org/10.3390/s21041109>.
- J. Zhang, J. Zhao, Immuno-biosensor, in: G. Li (Ed.), *Nano-inspired Biosensors for Protein Assay with Clinical Applications*, 2018, Elsevier, 2019, pp. 115–137.
- M.-J. Jeng, M. Sharma, Y.-C. Li, Y.-C. Lu, C.-Y. Yu, C.-L. Tsai, S.-F. Huang, L.-B. Chang, C.-S. Lai, Surface acoustic wave sensor for c-reactive protein detection, *Sensors* 20 (2020), <https://doi.org/10.3390/s20226640>.
- M. Agostini, F. Amato, M.L. Vieri, G. Greco, I. Tonazzini, L. Baroncelli, M. Caleo, E. Vannini, M. Santi, G. Signore, M. Cecchini, Glial-fibrillary-acidic-protein (GFAP) biomarker detection in serum-matrix: Functionalization strategies and detection by an ultra-high-frequency surface-acoustic-wave (UHF-SAW) lab-on-chip, *Biosens. Bioelectron.* 172 (2021), 112774, <https://doi.org/10.1016/j.bios.2020.112774>.
- D. Matatagui, Á. Bastida, M.C. Horrillo, Novel SH-SAW biosensors for ultra-fast recognition of growth factors, *Biosensors* 12 (2021), <https://doi.org/10.3390/bios12010017>.
- M.J. Jeng, Y.C. Li, M. Sharma, C.W. Chen, C.L. Tsai, Y.H. Lin, C.S. Lai, A surface acoustic wave sensor with a microfluidic channel for detecting C-reactive protein, *Chemosensors* 9 (5) (2021) 106, <https://doi.org/10.3390/chemosensors9050106>.
- Y. Jiang, C.Y. Tan, S.Y. Tan, M.S.F. Wong, Y.F. Chen, L. Zhang, Y.J. Tan, SAW sensor for Influenza A virus detection enabled with efficient surface functionalization, *Sens. Actuators B Chem.* 209 (2015) 78–84, <https://doi.org/10.1016/j.snb.2014.11.103>.
- H.J. Lee, K. Namkoong, E.C. Cho, C. Ko, J.C. Park, S.S. Lee, Surface acoustic wave immunosensor for real-time detection of hepatitis B surface antibodies in whole blood samples, *Biosens. Bioelectron.* 24 (2009) 3120–3125, <https://doi.org/10.1016/j.bios.2009.04.009>.
- J.T. Baca, V. Severns, D. Lovato, D.W. Branch, R.S. Larson, Rapid detection of Ebola virus with a reagent-free, point-of-care biosensor, *Sensors* 15 (2015) 8605–8614, <https://doi.org/10.3390/s150408605>.
- S. Dolai, M. Tabib-Azar, 433 MHz Lithium Niobate microbalance aptamer-coated whole Zika virus sensor with 370 Hz/ng sensitivity, *IEEE Sens. J.* 20 (8) (2019) 4269–4274, <https://doi.org/10.1109/JSEN.2019.2961611>.
- M. Bisoffi, B. Hjelle, D.C. Brown, D.W. Branch, T.L. Edwards, S.M. Brozik, V. S. Bondu-Hawkins, R.S. Larson, Detection of viral bioagents using a shear horizontal surface acoustic wave biosensor, *Biosens. Bioelectron.* 23 (2008) 1397–1403, <https://doi.org/10.1016/j.bios.2007.12.016>.
- M. Agostini, F. Lunardelli, M. Gagliardi, A. Miranda, L. Lamanna, A.G. Luminare, F. Gambineri, M. Lai, M. Pistello, M. Cecchini, Surface-acoustic-wave (SAW) induced mixing enhances the detection of viruses: application to measles sensing in whole human saliva with a saw lab-on-a-chip, *Adv. Funct. Mater.* (2022) 2201958, <https://doi.org/10.1002/adfm.202201958>.
- J.C. Pyun, H. Beutel, J.U. Meyer, H.H. Ruf, Development of a biosensor for E. coli based on a flexural plate wave (FPW) transducer, *Biosens. Bioelectron.* 13 (1998) 839–845, [https://doi.org/10.1016/S0956-5663\(98\)00050-5](https://doi.org/10.1016/S0956-5663(98)00050-5).
- K.S. Chang, C.K. Chang, C.Y. Chen, A surface acoustic wave sensor modified from a wireless transmitter for the monitoring of the growth of bacteria, *Sens. Actuators B Chem.* 125 (1) (2007) 207–213, <https://doi.org/10.1016/j.snb.2007.02.007>.
- E. Berkenpas, P. Millard, M. Pereira da Cunha, Detection of Escherichia coli O157:H7 with langasite pure shear horizontal surface acoustic wave sensors, *Biosens. Bioelectron.* 21 (2006) 2255–2262, <https://doi.org/10.1016/j.bios.2005.11.005>.
- N. Moll, E. Pascal, D.H. Dinh, J.-P. Pillot, B. Bennetau, D. Rebière, D. Moynet, Y. Mas, D. Mossalayi, J. Pistré, C. Déjous, A love wave immunosensor for whole E. coli bacteria detection using an innovative two-step immobilisation approach, *Biosens. Bioelectron.* 22 (2007) 2145–2150, <https://doi.org/10.1016/j.bios.2006.09.032>.
- L. Lamanna, F. Rizzi, V.R. Bhethanabotla, M. De Vittorio, Conformable surface acoustic wave biosensor for E-coli fabricated on PEN plastic film, *Biosens. Bioelectron.* 163 (2020), 112164, <https://doi.org/10.1016/j.bios.2020.112164>.
- M. Vouga, G. Greub, Emerging bacterial pathogens: the past and beyond, *Clin. Microbiol. Infect.* 22 (2016) 12–21, <https://doi.org/10.1016/j.cmi.2015.10.010>.
- [21] S. Doron, S.L. Gorbach, S. L., *Bacterial infections: overview*. International Encyclopedia of Public Health, 273 (2008).
- D. Chauhan, S.R. Shames, *Pathogenicity and Virulence of: Intracellular replication and host response*, *Virulence* 12 (2021) 1122–1144.

- [23] K. Paranjape, S. Lévesque, S.P. Faucher, Bacterial antagonistic species of the pathogenic genus isolated from cooling tower, *Microorganisms* 10 (2022), <https://doi.org/10.3390/microorganisms10020392>.
- [24] H. Li, S. Li, W. Tang, Y. Yang, J. Zhao, S. Xia, W. Zhang, H. Wang, Influence of secondary water supply systems on microbial community structure and opportunistic pathogen gene markers, *Water Res.* 136 (2018) 160–168, <https://doi.org/10.1016/j.watres.2018.02.031>.
- [25] D.T. Linsak, D. Kese, D. Broznic, D.V. Lusic, A. Cenov, M. Moric, I. Gobin, Sea water whirlpool spa as a source of Legionella infection, *J. Water Health* 19 (2021) 242–253, <https://doi.org/10.2166/wh.2021.150>.
- [26] A.M. Correia, J.S. Ferreira, V. Borges, A. Nunes, B. Gomes, R. Capucho, J. Gonçalves, D.M. Antunes, S. Almeida, A. Mendes, M. Guerreiro, D.A. Sampaio, L. Vieira, J. Machado, M.J. Simões, P. Gonçalves, J.P. Gomes, Probable Person-to-Person transmission of Legionnaires' disease, *N. Engl. J. Med.* 374 (2016) 497–498, <https://doi.org/10.1056/NEJMc1505356>.
- [27] E. Leoni, P.P. Legnani, Comparison of selective procedures for isolation and enumeration of Legionella species from hot water systems, *J. Appl. Microbiol.* 90 (2001) 27–33, <https://doi.org/10.1046/j.1365-2672.2001.01178.x>.
- [28] ISO, ISO 11731: Detection and Enumeration of Legionella, International Standards Organisation, Geneva, 2017.
- [29] E. Dietersdorfer, A. Kirschner, B. Schrammel, A. Ohradanova-Repic, H. Stockinger, R. Sommer, J. Walochnik, S. Cervero-Aragó, Starved viable but non-culturable (VBNC) Legionella strains can infect and replicate in amoebae and human macrophages, *Water Res.* 141 (2018) 428–438, <https://doi.org/10.1016/j.watres.2018.01.058>.
- [30] B. Casini, A. Baggiani, M. Totaro, A. Mansi, A.L. Costa, F. Aquino, M. Miccoli, P. Valentini, F. Bruschi, P.L. Lopalco, G. Privitera, Detection of viable but non-culturable legionella in hospital water network following monochloramine disinfection, *J. Hosp. Infect.* 98 (2018) 46–52, <https://doi.org/10.1016/j.jhin.2017.09.006>.
- [31] L. Alleron, N. Merlet, C. Lacombe, J. Frère, Long-term survival of Legionella pneumophila in the viable but nonculturable state after monochloramine treatment, *Curr. Microbiol.* 57 (2008) 497–502, <https://doi.org/10.1007/s00284-008-9275-9>.
- [32] S. Bavari, S. Mirkalantari, F. Masjedjan Jazi, D. Darban-Sarokhalil, B. Golnari Marani, Risk assessment and quantitative measurement along with monitoring of in hospital water sources, *New Microbes New Infect.* 45 (2022), 100948, <https://doi.org/10.1016/j.nmni.2021.100948>.
- [33] C. Young, D. Smith, T. Wafer, B. Crook, Rapid testing and interventions to control proliferation following a legionnaires' disease outbreak associated with cooling towers, *Microorganisms* 9 (2021), <https://doi.org/10.3390/microorganisms9030615>.
- [34] M. Farhat, R.A. Shaheed, H.H. Al-Ali, A.S. Al-Ghamdi, G.M. Al-Hamaqi, H.S. Maan, Z.A. Al-Mahfooth, H.Z. Al-Seba, Legionella confirmation in cooling tower water. Comparison of culture, real-time PCR and next generation sequencing, *Saudi Med. J.* 39 (2018) 137–141, <https://doi.org/10.15537/smj.2018.2.21587>.
- [35] A. Meneghello, A. Sonato, G. Ruffato, G. Zacco, F. Romanato, A novel high sensitive surface plasmon resonance Legionella pneumophila sensing platform, *Sens. Actuators B Chem.* 250 (2017) 351–355, <https://doi.org/10.1016/j.snb.2017.04.177>.
- [36] D. Sboui, M. Souiri, S. Reynaud, S. Palle, M.B. Ismail, T. Epalle, A. Othmane, Characterisation of electrochemical immunosensor for detection of viable not-culturable forms of Legionella pneumophila in water samples, *Chem. Pap.* 69 (11) (2015) 1402–1410, <https://doi.org/10.1016/j.tsf.2010.08.056>.
- [37] Y. Honda, R. Ichikawa, Y.J. Choi, K. Murakami, K. Takahashi, T. Noda, M. Saito, Detection system for Legionella bacteria using photogate-type optical sensor, *Jpn. J. Appl. Phys.* 61 (SD) (2022) SD1010.
- [38] E. Howe, G. Harding, A comparison of protocols for the optimisation of detection of bacteria using a surface acoustic wave (SAW) biosensor, *Biosens. Bioelectron.* 15 (2000) 641–649, [https://doi.org/10.1016/S0956-5663\(00\)00116-0](https://doi.org/10.1016/S0956-5663(00)00116-0).
- [39] M. Totaro, P. Valentini, A.L. Costa, L. Frenzo, A. Cappello, B. Casini, M. Miccoli, G. Privitera, A. Baggiani, Presence of Legionella spp. in hot water networks of different Italian residential buildings: a three-year survey, *Int. J. Environ. Res. Public Health* 14 (2017), <https://doi.org/10.3390/ijerph14111296>.
- [40] Legionnaires' disease Annual Epidemiological Report for 2019, European Centre for Disease Prevention and Control.
- [41] M. Agostini, G. Greco, M. Cecchini, Full-SAW microfluidics-based lab-on-a-chip for biosensing, *IEEE Access* 7 (2019) 70901–70909, <https://doi.org/10.1109/ACCESS.2019.2919000>.
- [42] M. Agostini, G. Greco, M. Cecchini, A Rayleigh surface acoustic wave (R-SAW) resonator biosensor based on positive and negative reflectors with sub-nanomolar limit of detection, *Sens. Actuators B Chem.* 254 (2018) 1–7, <https://doi.org/10.1016/j.snb.2017.07.014>.
- [43] P. Delgado-Viscogliosi, T. Simonart, V. Parent, G. Marchand, M. Dobbelaere, E. Pierlot, V. Pierzo, F. Menard-Sczebara, E. Gaudard-Ferveur, K. Delabre, J. M. Delattre, Rapid method for enumeration of viable Legionella pneumophila and other Legionella spp. in water, *Appl. Environ. Microbiol.* 71 (2005) 4086–4096, <https://doi.org/10.1128/AEM.71.7.4086-4096.2005>.

Mariacristina Gagliardi received her Master Degree in Chemical Engineering (2006) and the PhD degree in Chemical and Materials Engineering (2010) at the University of Pisa, working on the experimental and computational analysis of materials for advanced cardiovascular applications. She was a postdoctoral fellow at the University of Pisa from 2010 to 2011, at the Center for Nanotechnology Innovation @NEST (Istituto Italiano di Tecnologia) from 2011 to 2013, at the Center for Micro Bio-Robotics @SSSA (Isti-tuto Italiano di Tecnologia) from 2013 to 2015, at IMT School for Advanced Studies Lucca from 2015 to

2019. To date, she is a post-doctoral fellow at the NEST Istituto Nanoscienze-CNR. Her research activities focus on the development of functional nanoparticles with applications in biosensors and nanomedicine.

Matteo Agostini, CEO and co-founder of INTA Systems, a “Scuola Normale Superiore” University of Pisa (SNS) and National Research Council of Italy (CNR) spin-off. Experience as academic researcher. Education: Ph. D. in Molecular Biophysics and Nanoscience, M. Sc. in Industrial Nanotechnology, and B. Sc. in Electronics Engineering. Currently leading INTA Systems, which develops and commercializes novel devices for rapid analysis on chip, such as the detection of viruses, bacteria, and biomarkers.

Francesco Lunardelli was born in La Spezia (SP) on 07/03/1995. He obtained his bachelor degree in Physics at the University of Pisa (Italy) in 2017. Then he got the master's degree in Condensed Matter Physics at the University of Pisa (Italy) in 2020. From September 2020 to September 2021 He worked as research fellow at CNR-Nano (Pisa, Italy). Currently, He is a Ph.D. student in Nanosciences at the Scuola Normale Superiore (Pisa, Italy). His research is focused on developing biosensors based on surface acoustic wave (SAW) technology, with a particular focus on real-time sensing in liquid environments.

Leonardo Lamanna currently is a researcher at the Università del Salento in the department of engineering of innovation. He got a PhD in Engineering of materials and nanotechnology at the University of Salento in collaboration with Istituto Italiano di Tecnologia. During the PhD, he was scholar research at the University of South Florida in the department of chemical & biomedical engineering. After the PhD he has been PostDoc in Pisa and Milan. His interests and activities are related to the development and application of new materials, technology and device to be applied in wearables and edible electronics.

Dr. Alessio Miranda received his degree in Electrical engineering (2004) and PhD in Physics (2009) both at Polytechnic University of Milan, Italy. He then joined a number of institutions including CEMES-CNRS, LAAS-CNRS, Weizmann Institute of Physics, Tyndall National Institute, University Duisburg-Essen, EPFL, IMEC, and CNR-Nano where he worked on research projects related to the optical and electrical properties of low-dimensional systems (graphene, MXene, Si/Ge heterostructures, quantum dots), colorimetry, surface acoustic waves from both an experimental (fabrication, electrical, structural and optical characterization) and computational approach. He is now continuing his research activity in Photonics in the Netherlands. Dr. Miranda is member of the DPG and the EPS and is co-author of about thirty publications on scientific journals and conference proceedings.

Agostino Bazzichi is a Biologist with post-graduate Specialization in Microbiology and Virology. After 9 years of attendance at the Department of Biomedicine of the University of Pisa (graduate student, fellow and contract researcher) he began his freelance activity in the field of environmental microbiology and food and beverage hygiene. For about 25 years he has been collaborating with a private analysis laboratory where he holds the position of head of the biological area His main interests are applied microbiology, ecotoxicology, biological safety in workplaces, food hygiene and microbiological quality of the water (with particular regard to Legionella and other pathogens), as well as participation in funded researches (European and Italian). He has published about 30 refereed papers.

Antonella Giuliana Luminare is a Chemist with Master Degree in Analytical Chemistry at the University of Pisa. She works in the Research Department of ARCHA srl since 2018, a private research centre, working on applied research regarding environmental chemistry, materials science, set up and optimization of industrial processes and products. She is involved in technical and experimental aspect of research project, in writing technical propose of project and periodic reports.

Fabrizio Cervelli is a biologist with a PhD in Cellular and Molecular Pathology. He attended for 7 years the Department of Biomedicine of the University of Pisa (graduate student, fellow to PhD student). Since 1998, he has been working as a freelancer in the field of analysis and consultancy in the field of environment, hygiene, health and safety at work. For over 20 years he has been dealing with issues related to the problem of Legionella in water networks with consulting and analysis. He has participated in numerous national research projects, in particular he is the creator and partner of a project funded by the Tuscan region for the control and management of Legionella in drinking water.

Francesca Gambineri is an Industrial Chemist. After 1 years of attendance at the Department of Chemistry of the University of Pisa she began head of Research Department of ARCHA srl, a private research centre, working on applied research regarding environmental chemistry, materials science, set up and optimization of industrial processes and products. She organizes and coordinates partnership in research projects financed by EU, national and regional funding, writing technical proposal and periodic reports. She is inventor in 10 patents and she has published more than 30 refereed papers. She is thesis supervisor in 17 thesis of University of Pisa (Chemistry, Industrial Chemistry and Engineering).

Michele Totaro, Biologist, specializing in Microbiology and Virology. In 2014 he attended a scholarship on the topic of water risk assessment from Legionella and other waterborne pathogens. Research was performed at the Institute of Hygiene of the Department of

Translational Research and New Technologies in Medicine and Surgery (University of Pisa). In 2016 he attended a three-year research fellowship at the same Department, studying the issue of environmental microbiological risk with particular reference to healthcare facilities, industrial and food production. He also addressed the issues of infectious risk management from drug-resistant microorganisms in hospital setting. In 2019 he won a research grant at the same Department in which he implemented the technological measures for the management of water risk in healthcare areas, including new experimental systems for the rapid identification of *Legionella* in several environmental matrices (Sensor Project of the Tuscany Region). He is the author of 48 publications in national and international journals. He attended several conferences organized by Italian and European scientific societies. Member of the Italian Society of Hygiene since 2013; the European Society of Clinical Microbiology since 2016 and the Italian Society of Microbiology since 2020.

Giuseppantonio Maisetta is a senior Researcher in the Department of Translational Research and New Technologies in Medicine and Surgery of University of Pisa. He teaches Microbiology and Clinical Microbiology in degree courses in Pharmacy, Health care professions and Specialization course in Microbiology and Virology. He also works as Biologist in the Microbiology and Micology Unit of Pisa University Hospital (Azienda Ospedaliera Universitaria Pisana). His main research interests include natural molecules with antimicrobial and/or immunomodulatory activity as new classes of therapeutic agents against infectious diseases; ii) microbial biofilms and biofilm-associated infections; iv) use of beneficial bacteria (i.e., probiotics) to counteract the pathogenicity and the virulence of bacterial pathogens (bacteriotherapy); v) sensors for pathogen detection. He is Associate Editor of the Journal "Frontiers in Microbiology", Section Board member of the journals "Antibiotics" and "Microorganisms". He is co-author of 64 peer-reviewed papers in international journals. H-index 29, citations 2383 (Scopus 10 October 2022).

Prof. Giovanna Batoni In 1987, has awarded a Master degree in Biological Sciences at the University of Pisa, Italy, with full marks. In 1933, she awarded a PhD degree in "Experimental oncology and morphology of tumors" and soon after, she entered in the permanent staff of the University of Pisa as Assistant Professor. In 2001, she become Associate Professor of Microbiology and since 2019, she is Full Professor in the same discipline. She has spent several periods abroad as visiting fellow at the Swedish Institute for Infectious Disease Control, and at the Microbiology and Tumor Biology Center" of Karolinska Institute, Stockholm, Sweden. She has a broad background in microbiology, virology, host-pathogen interaction, immunology and infectious diseases as witnessed by numerous publications in high impact factor journals. As PI or co-investigator, she took part to several Research Programs funded by National and International Agencies, Foundations or private Companies. She was elected member of the "Scientific Committee" of the Research Area 06: Medical Sciences of the University of Pisa (years 2004–2008 and 2020–2022) and nominated member of the Advisory board of the European Project (Framework Program 7)

"Biofilm alliance" (years 2011–2016). In several occasions, acted as reviewer of Grant applications for National and International Grant-Agencies. Since more than 20 years, Prof. Batoni is leading a research groups at the Department of Translational Research and New Technologies in Medicine and Surgery, Microbiology Section, University of Pisa; her main research interests include: i) natural molecules with antimicrobial and/or immunomodulatory activity as new classes of therapeutic agents against infectious diseases; ii) interaction between infectious agents and natural and specific immune system of the host; iii) microbial biofilms and biofilm-associated infections; iv) use of beneficial bacteria (i.e., probiotics) to counteract the pathogenicity and the virulence of bacterial pathogens (bacteriotherapy); v) sensors for pathogen detection. She is Associate Editor of the Journal "Frontiers in Microbiology", Section Board member of the journals "Antibiotics" and "International Journal of Molecular Sciences" and Topical Advisory Panel Member of the "International Journal of Molecular Sciences". She is co-author of 92 peer-reviewed papers in international journals and more that 130 communications in National and International Conferences some of which as invited speaker. H-index 32, citations 3342 (Scopus 10 October 2022).

Mauro Pistello is Full Professor of Microbiology and Clinical Microbiology at the School of Medicine of University of Pisa and Adjunct Professor the University "Vita e Salute" San Raffaele, Milan, Italy. He has worked and served as a teacher for the European community and various American and European research institutions. He is Director of the Clinical Virology Unit, Pisa University Hospital (Azienda Ospedaliera Universitaria Pisana), Director of the Retrovirus Center, Department of Translational Research, University of Pisa, Director of the Specialization School in Microbiology and Virology, Director of the PhD Course in Clinical and Translational Sciences and member of the Italian Ministry of Health and the National Medical Research Council of Singapore. His main interests are virus-host relationships, pathogenesis and therapy of retroviruses, lentiviruses, and hepatitis viruses. He was involved in the development of novel approaches for personalized medicine, gene therapy and vaccination. He has published over 200 refereed papers as well as chapters in scientific books and has served as referee for various national and international funding research agencies and scientific journals.

Marco Cecchini. Born in Italy in 1975, he received his Master degree in Physics from the Physics Department of the University of Pisa (Italy) in 1999, and PhD in Condensed Matter Physics from the Scuola Normale Superiore (Italy) in 2006. Currently, he is senior researcher and member of the scientific council of the Nanoscience Institute (Pisa, Italy) of the Italian National Research Council (CNR), CTO of INTA srl (a joint spin-off company of the CNR and Scuola Normale Superiore) and Lecturer of Biomaterial Science at the University of Pisa (Biology Department, Laurea Degree Course in Biotechnology). His main research interests are: development of nanomaterials for brain pathologies and nerve regeneration; development of surface-acoustic-wave devices for microfluidics and sensing applications.