

High-resolution gas phase spectroscopy with a distributed feedback terahertz quantum cascade laser

Cite as: Appl. Phys. Lett. **89**, 061115 (2006); <https://doi.org/10.1063/1.2335803>

Submitted: 29 March 2006 . Accepted: 23 June 2006 . Published Online: 10 August 2006

H.-W. Hübers, S. G. Pavlov, H. Richter, A. D. Semenov, L. Mahler, A. Tredicucci, H. E. Beere, and D. A. Ritchie



View Online



Export Citation

ARTICLES YOU MAY BE INTERESTED IN

[Terahertz gas spectroscopy through self-mixing in a quantum-cascade laser](#)

Applied Physics Letters **109**, 191101 (2016); <https://doi.org/10.1063/1.4967435>

[Terahertz heterodyne receiver based on a quantum cascade laser and a superconducting bolometer](#)

Applied Physics Letters **86**, 244104 (2005); <https://doi.org/10.1063/1.1949724>

[High-resolution heterodyne spectroscopy using a tunable quantum cascade laser around 3.5 THz](#)

Applied Physics Letters **98**, 231109 (2011); <https://doi.org/10.1063/1.3599518>

High-resolution gas phase spectroscopy with a distributed feedback terahertz quantum cascade laser

H.-W. Hübers,^{a)} S. G. Pavlov, H. Richter, and A. D. Semenov
German Aerospace Center (DLR), Rutherfordstr. 2, 12489 Berlin, Germany

L. Mahler and A. Tredicucci
NEST, CNR-INFM and Scuola Normale Superiore, Piazza dei Cavalieri 7, 56126 Pisa, Italy

H. E. Beere and D. A. Ritchie
Cavendish Laboratory, University of Cambridge, Madingley Road, Cambridge CB3 0HE, United Kingdom

(Received 29 March 2006; accepted 23 June 2006; published online 10 August 2006)

The quantum cascade laser is a powerful, narrow linewidth, and continuous wave source of terahertz radiation. The authors have implemented a distributed feedback device in a spectrometer for high-resolution gas phase spectroscopy. Amplitude as well as frequency modulation schemes have been realized. The absolute frequency was determined by mixing the radiation from the quantum cascade laser with that from a gas laser. The pressure broadening and the pressure shift of a rotational transition of methanol at 2.519 THz were measured in order to demonstrate the performance of the spectrometer. © 2006 American Institute of Physics. [DOI: 10.1063/1.2335803]

High-resolution gas phase spectroscopy at terahertz frequencies is a powerful tool for investigations of the structure and energy levels of molecules and atoms. Besides information on the species itself, important information on Doppler and pressure broadening can be obtained from terahertz spectra. These data are a prerequisite for the interpretation of spectra obtained from astronomical sources or planetary atmospheres including the Earth.¹ In the low terahertz region different methods have been developed, which are mostly based on fundamental microwave oscillators (for example, backward wave oscillators or klystrons) or harmonic generation from these sources.² In contrast, spectroscopy above 2 THz is hampered by the lack of frequency tunable, continuous wave, powerful, and narrow linewidth radiation sources. Several technologies providing tunable terahertz radiation have been demonstrated. One approach is to combine the radiation from two CO₂ lasers in a metal-insulator-metal diode, which generates a difference frequency in the terahertz range. Frequency tunability of about 40 GHz is achieved by adding a tunable microwave source.³ The drawbacks of this technique are the small amount of terahertz power (typically a few tenths of a microwatt) and the need for a sophisticated frequency stabilization of the CO₂ lasers. Another approach is based on sideband generation by mixing the radiation of an optically pumped terahertz gas laser with radiation of a microwave source or a backward wave oscillator in a Schottky barrier diode.^{4–6} This yields more but still little output power (typically several microwatt) and again suffers from complexity. In addition, the frequency coverage is limited because only powerful gas laser lines can be used for sideband generation. The sensitivity of an instrument relying on either of these techniques is ultimately limited by the available power. Terahertz time domain spectroscopy is an alternative technology which is based on lasers emitting femtosecond pulses. These are used to generate broadband (up to several terahertz) pulses.^{7,8} However, the spectral resolution of this technique is typically 1–10 GHz. The most

sensitive method is laser magnetic resonance spectroscopy that makes use of the Zeeman effect but is limited to paramagnetic species.⁹ The recently developed terahertz quantum cascade laser¹⁰ (QCL) has attractive features for gas phase spectroscopy, namely, its intrinsic linewidth of less than 20 kHz (Refs. 11–13) and high output power.¹⁴ In this letter we describe a high-resolution terahertz spectrometer based on a QCL and present first spectroscopic results.

The QCL is designed for an operation frequency around 2.5 THz. It is based on a GaAs/AlGaAs superlattice and a plasmon-type waveguide. The design follows the so-called bound-to-continuum approach.¹⁵ Design and fabrication are identical with those described in Ref. 16. The active medium is formed by 110 repeat units of the superlattice (total thickness of 15 μm) covered on top by a Cr/Au layer. This layer is patterned into a series of narrow slits with half-wavelength period to create a distributed feedback (DFB) structure. The other boundary of the waveguide consists of two highly doped GaAs layers located between the substrate and the active medium. The resonator is a mesa-etched, 240 μm wide ridge with a length of 2.5 mm defined by cleaving. The laser is soldered to a copper bar, wire bonded, and mounted in a holder with a Winston cone (f number=6) close to the outcoupling facet of the laser. The QCL is operated in a mechanical cryocooler (model SRDK-408D from Sumitomo Heavy Industries Ltd.). In order to minimize vibrations it is mechanically isolated from the coldfinger by copper wires. The cooler has a heat extraction capacity of 1 W at 4.2 K. Since the input power of the laser is 5–10 W, the smallest achievable temperature at the position of the QCL is ~ 20 K during laser operation. The laser threshold is about 80 A/cm² at 20 K, the maximum output power is 6 mW, and the laser works up to 58 K in continuous wave. The emission is single mode at all injection currents and operating temperatures. The inherent linewidth of the QCL is less than 20 kHz within a 4 ms integration time. It increases to ~ 0.5 MHz within an integration time of 300 ms. This is sufficient for the Doppler limited gas phase spectroscopy of many molecules. For example, the Doppler limited linewidth

^{a)}Electronic mail: heinz-wilhelm.huebers@dlr.de

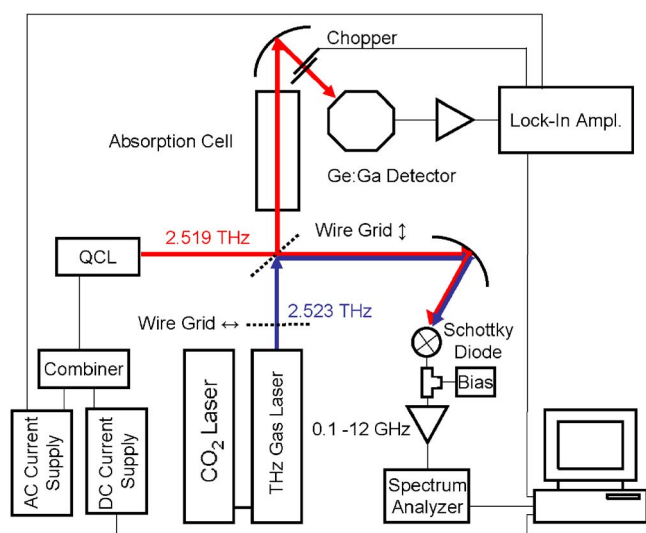

FIG. 1. (Color online) Terahertz spectrometer with QCL as radiation source.

of $^{12}\text{CH}_3^{16}\text{OH}$ is 5.5 MHz at 2.5 THz and 300 K.

The setup of the spectrometer is sketched in Fig. 1. The frequency of the QCL can be tuned by either changing its operation temperature or by applying a sweep current. In general the temperature of the QCL is set, and the current is swept in steps between 0.05 and 0.2 mA corresponding to frequency steps of 0.5–2 MHz. The broader the line, the larger the chosen step size was. By this means each absorption profile consists of 20–100 resolution elements. About 90% of the radiation from the QCL is reflected by a wire grid into a 0.5 m long absorption cell. The cell is equipped with two polyethylene windows and the pressure is measured with a capacitance manometer. For each measurement the cell was filled with methanol gas at a certain pressure and sealed off. The transmitted radiation is collimated by an off-axis parabolic mirror and detected with a Ge:Ga photoconductive detector. In order to measure the absorption profile directly the transmitted radiation is mechanically chopped (amplitude modulation) in front of the Ge:Ga detector and detected with a lock-in amplifier. In this case the base line is not flat due to the current dependent output power of the QCL. Alternatively, the frequency of the QCL can be modulated by superimposing a sinusoidal current (frequency f up to 50 kHz) on the dc sweep current. The signal is detected at $2f$ with a lock-in amplifier. By this means the tilted base line can be removed as well as the $1/f$ noise. This scheme is more precise than measuring the power from the QCL as a function of current and normalizing the data with respect to the output power. A small part ($\sim 10\%$) of the radiation from the QCL is transmitted through the wire grid. This is superimposed with the radiation from an optically pumped terahertz gas laser operating on the methanol emission line at 2.522 781 6 THz [pump line of the CO_2 laser: 9P36 (Ref. 17)]. At the output of the gas laser a grid with wires oriented perpendicularly to the wires of the first grid is used to define the polarization in a way that it is reflected by the first grid. It was verified that radiation from the gas laser did not reach the Ge:Ga detector. The radiation from both lasers is focused onto a GaAs Schottky diode with a quasi-optical 4λ corner cube antenna.¹⁸ The signal at the difference frequency is amplified, and its frequency is measured with a spectrum analyzer. By this means the absolute frequency for each data

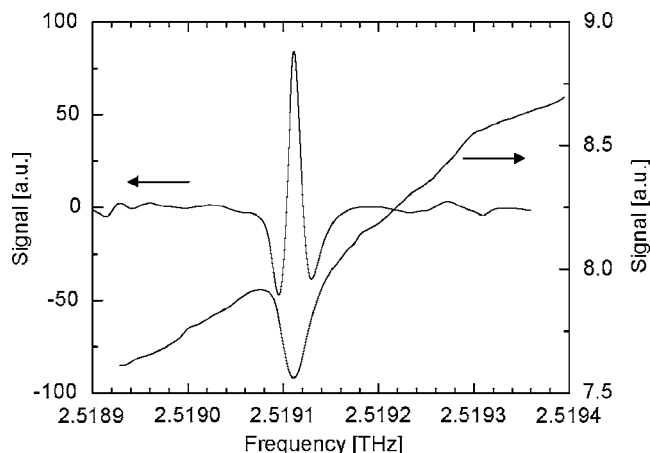

FIG. 2. Typical absorption spectra of the CH_3OH transition ($p=150$ Pa) measured with amplitude modulation and frequency modulation. In the case of amplitude modulation the tilted base line is due to the change of power from the QCL with changing current. The base line drift can be almost completely removed by frequency modulation of the QCL.

point is measured. This is especially important because the frequency tuning of the QCL is not linear with current. A frequency range of 2.517–2.521 THz is available from this QCL by changing temperature and current.

As a demonstration we have performed absorption spectroscopy of the P transition $|E_1, v=0, n=2, K=2, J=20\rangle \leftarrow |E_1, v=0, n=1, K=3, J=21\rangle$ of the methanol isotopomer $^{12}\text{CH}_3^{16}\text{OH}$. Here E_1 is the symmetry species, v is the vibrational state, n denotes the torsional state, and K and J are the usual angular momentum quantum numbers.¹⁹ In Fig. 2 two typical spectra are shown. One is measured with amplitude modulation and the other is measured with frequency modulation. As can be seen the latter technique eliminates the tilted base line to a large extent. Figure 3 shows the absorption line along with a Voigt profile fitted to the measured profile. As can be seen from the residue (measurement minus fit) the agreement is very good. The self-pressure broadening of the methanol line was determined by measuring its profile at different pressures up to 1000 Pa and determining the full width at half maximum (FWHM). A least squares fit to the

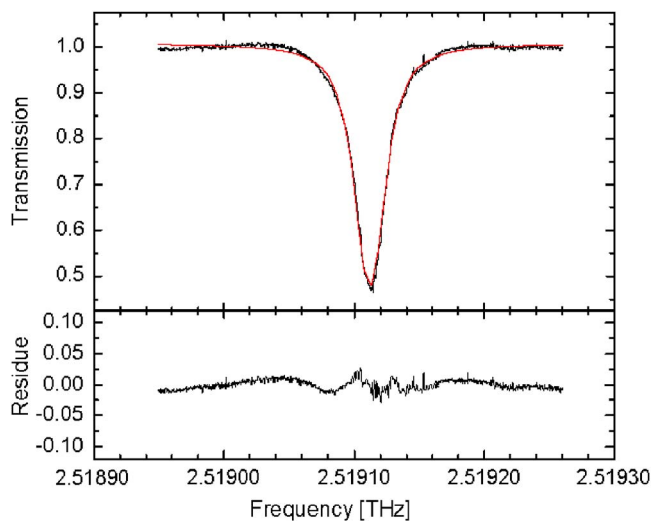

FIG. 3. (Color online) CH_3OH absorption spectrum measured at 100 Pa after subtraction of the tilted base line. The straight line is a fit of a Voigt profile to the absorption line. The lower panel shows the residue after subtraction of the fit from the measured data.

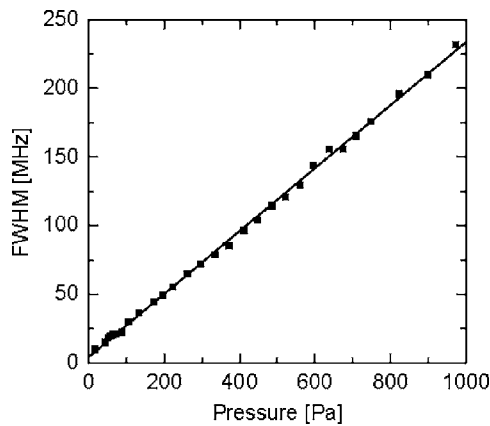

FIG. 4. FWHM of the CH_3OH transition as a function of pressure.

FWHM data yields a pressure broadening coefficient of $229(2)$ kHz/Pa (Fig. 4). This is similar to pressure broadening coefficients of other methanol lines [$265.6(2)$ kHz/Pa at 76 GHz (Ref. 20) and 290 kHz/Pa at 2.524 THz (Ref. 21)]. The center frequency of the absorption line was determined from least squares fits of a Voigt profile to the measured profile. In Fig. 5 the center frequency is plotted as a function of the pressure. The straight line is a least squares fit to the data. From this fit the pressure shift is determined to be $10(2)$ kHz/Pa and the zero pressure frequency is determined to be $2.519\,112(1)$ THz. Both values agree well with other published data [6 kHz/Pa measured for a different line than the one here²² and $2.519\,107(2)$ THz (Ref. 19)]. It is worth noting that the accuracy is not limited by the frequency stability or linewidth of the QCL because the typical error in the determination of the line peak from the fit is less than ± 150 kHz (95% rms). Instead, it is the frequency accuracy of the gas laser. This is limited by the precision with which it is possible to tune the gas laser line to its peak power (approximately ± 1 MHz).

In summary, we have realized a terahertz spectrometer for high-resolution gas phase spectroscopy based on a DFB QCL as the radiation source. Frequency calibration of the spectra is achieved by instantaneously measuring the frequency difference between the QCL and a terahertz gas laser.

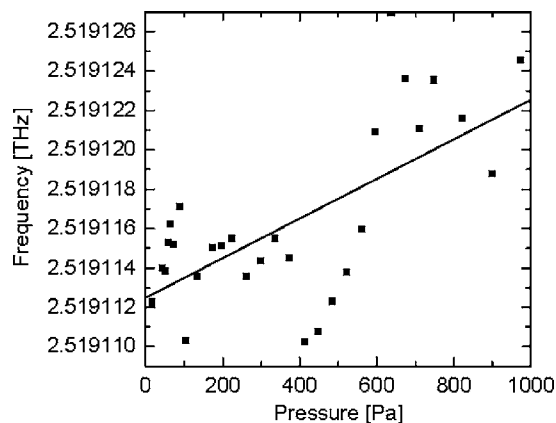

FIG. 5. Center frequency of the CH_3OH transition as a function of pressure. Note that the scatter of the data is not caused by the QCL but is due to the inaccuracy of the gas laser frequency which provides the reference.

Amplitude as well as frequency modulation schemes have been realized. While the first technique yields the true line shape, the second allows removal of the tilted base line. By replacing the gas laser with a phase locked, frequency tunable, multiplied microwave source, the frequency measurement can be made more accurate as well as more broadband. We have measured the transition frequency, pressure broadening and pressure shift parameters of a methanol line at 2.5 THz. The comparison of our data with other spectroscopic data shows good agreement and demonstrates that the terahertz QCL is a very useful source for high-resolution gas phase spectroscopy.

This work was supported in part by the Investitionsbank Berlin and the European Commission through the PASR project “TeraSec,” the IP project “Teranova,” and the Marie Curie RTN “Poise.”

- ¹*Spectroscopy from Space*, edited by J. Demaison, K. Sarka, and E. H. Cohen (Kluwer, Dordrecht, 2001), Vol. 20.
- ²F. Lucia, in *Sensing with Terahertz Radiation*, edited by D. Mittleman (Springer, Berlin, 2003), Vol. 85, p. 39.
- ³K. M. Evenson, D. A. Jennings, and M. D. Vanek, in *Frontiers of Laser Spectroscopy of Gases*, edited by A. C. P. Alves, J. M. Brown, and J. M. Hollas (Kluwer, Dordrecht, 1988), Vol. 234, p. 43.
- ⁴P. Verhoeve, E. Zwart, M. Verslius, J. Ter Meulen, W. L. Meerts, A. Dymanus, and D. Mclay, *Rev. Sci. Instrum.* **61**, 1612 (1990).
- ⁵G. A. Blake, K. B. Laughlin, R. C. Cohen, K. L. Busarow, D.-H. Gwo, C. A. Schmuttenmaer, D. W. Steyert, and R. J. Saykally, *Rev. Sci. Instrum.* **62**, 1701 (1991).
- ⁶R. Gendriesch, F. Lewen, G. Winnewisser, and J. Hahn, *J. Mol. Spectrosc.* **203**, 205 (2000).
- ⁷D. M. Mittleman, R. H. Jacobsen, R. Neelamani, R. G. Baraniuk, and M. C. Nuss, *Appl. Phys. B: Lasers Opt.* **B67**, 379 (1998).
- ⁸A. Bartels, A. Thoma, C. Janke, A. Dreyhaupt, S. Winnerl, and M. Helm, *Opt. Express* **14**, 430 (2006).
- ⁹K. M. Evenson, R. J. Saykally, D. A. Jennings, R. F. Curl, Jr., and J. M. Brown, in *Chemical and Biochemical Applications of Lasers*, edited by C. Bradley Moore (Academic, New York, 1980), Vol. 5, p. 95.
- ¹⁰R. Köhler, A. Tredicucci, F. Beltram, H. E. Beere, E. H. Linfield, A. G. Davies, D. A. Ritchie, R. C. Iotti, and F. Rossi, *Nature (London)* **417**, 156 (2002).
- ¹¹A. Barkan, F. K. Tittel, D. M. Mittleman, R. Dengler, P. H. Siegel, G. Scalari, L. Ajili, J. Faist, H. E. Beere, E. H. Linfield, A. G. Davies, and D. A. Ritchie, *Opt. Lett.* **29**, 575 (2004).
- ¹²S. Barbieri, J. Alton, H. E. Beere, E. H. Linfield, D. A. Ritchie, S. Withington, G. Scalari, L. Ajili, and J. Faist, *Opt. Lett.* **29**, 1632 (2004).
- ¹³H.-W. Hübers, S. G. Pavlov, A. D. Semenov, R. Köhler, L. Mahler, A. Tredicucci, H. E. Beere, D. A. Ritchie, and E. H. Linfield, *Opt. Express* **13**, 5890 (2005).
- ¹⁴B. S. Williams, S. Kumar, Q. Hu, and J. L. Reno, *Electron. Lett.* **42**, 89 (2006).
- ¹⁵J. Faist, M. Beck, T. Aellen, and E. Gini, *Appl. Phys. Lett.* **78**, 147 (2001).
- ¹⁶L. Mahler, A. Tredicucci, R. Köhler, F. Beltram, H. E. Beere, E. H. Linfield, and D. A. Ritchie, *Appl. Phys. Lett.* **87**, 181101 (2005).
- ¹⁷N. G. Douglas, *Millimetre and Submillimetre Wavelength Lasers* (Springer, Berlin, 1989), Vol. 61, p. 73.
- ¹⁸H. P. Röser, H.-W. Hübers, T. W. Crowe, and W. C. B. Peatman, *Infrared Phys. Technol.* **35**, 451 (1994).
- ¹⁹G. Moruzzi, F. Strumia, P. Carneseccche, B. Carli, and M. Parlotti, *Infrared Phys.* **29**, 47 (1989).
- ²⁰P. Minguzzi, M. Tonelli, G. Carrara, and A. Di Lieto, *J. Mol. Spectrosc.* **109**, 395 (1985).
- ²¹A. D. Semenov, H.-W. Hübers, H. Richter, M. Birk, M. Krocka, U. Mair, K. Smirnov, G. Goltsman, and B. V. Voronov, *Physica C* **372-376**, 448 (2002).
- ²²G. Buffa, G. Moruzzi, and O. Tarrini, *Infrared Phys.* **27**, 349 (1987).