

## Drude Weight, Cyclotron Resonance, and the Dicke Model of Graphene Cavity QED

Luca Chirolli,<sup>1</sup> Marco Polini,<sup>2,\*</sup> Vittorio Giovannetti,<sup>1</sup> and Allan H. MacDonald<sup>3</sup>

<sup>1</sup>*NEST, Scuola Normale Superiore and Istituto Nanoscienze-CNR, I-56126 Pisa, Italy*

<sup>2</sup>*NEST, Istituto Nanoscienze-CNR and Scuola Normale Superiore, I-56126 Pisa, Italy*

<sup>3</sup>*Department of Physics, University of Texas at Austin, Austin, Texas 78712, USA*

(Received 30 July 2012; published 27 December 2012)

The unique optoelectronic properties of graphene make this two-dimensional material an ideal platform for fundamental studies of cavity quantum electrodynamics in the strong-coupling regime. The celebrated Dicke model of cavity quantum electrodynamics can be approximately realized in this material when the cyclotron transition of its 2D massless Dirac fermion carriers is nearly resonant with a cavity photon mode. We develop the theory of strong matter-photon coupling in this circumstance, emphasizing the essential role of a dynamically generated matter energy term that is quadratic in the photon field and absent in graphene's low-energy Dirac model.

DOI: [10.1103/PhysRevLett.109.267404](https://doi.org/10.1103/PhysRevLett.109.267404)

PACS numbers: 78.67.Wj, 42.50.Pq, 73.43.-f

**Introduction.**—Graphene, a 2D honeycomb crystal of carbon atoms [1], is emerging as an ideal platform to study light-matter interactions for both fundamental and applied purposes [2–5]. Recent experimental advances have made it possible to monolithically integrate graphene with optical microcavities [6,7], paving the way for cavity quantum electrodynamics (QED) [8] at the nanometer scale with graphene as an active medium. Graphene cavity QED offers a plethora of unique advantages. First, graphene is a highly tunable active medium [6] since its electrical and heat transport properties can be easily controlled by employing gates. Second, graphene offers many pathways to achieve the so-called strong-coupling regime of cavity QED [8]. These include [4,5] the exploitation of intrinsic Dirac plasmons or the combination of graphene with other plasmonic nanostructures. Finally, the active medium can be enriched by embedding inside planar cavities 2D vertical heterostructures [9] comprising graphene as well as other 2D crystals [10] such as MoS<sub>2</sub>, *h*-BN, etc.

A central role in cavity QED is played by the Dicke model [11], which describes a nondissipative closed system of identical two-level subsystems interacting with a single-mode radiation field. For a sufficiently strong light-matter coupling constant, the thermodynamic limit of the Dicke model exhibits a second-order quantum phase transition to a superradiant ground state (SPT) [12] with macroscopic photon occupation and coherent atomic polarization. Wide interest in these SPTs has emerged recently in the context of circuit QED [13–16] and ultracold atom gases in optical cavities [17,18]. When an external magnetic field is applied to a 2D electron system, transitions between states in full and empty Landau levels (LLs) are dispersionless, mimicking atomic transitions and enabling a condensed matter realization of the Dicke model. In particular, recent pioneering work [19,20] has shown that these systems can be driven toward the ultrastrong coupling [21] limit by tuning the cyclotron transition

energy of an ordinary parabolic-band 2D electron gas to resonance with the photonic modes of a terahertz metamaterial. The main scope of this work is to lay down a theory of the Dicke model of graphene cavity QED. This is not only a fundamental building block of cavity QED, but it also offers a number of intriguing twists when it is realized on a graphene platform.

The light-matter interaction in the Dicke Hamiltonian is linear in the vector potential  $A_{\text{em}}$  of the cavity. For condensed matter states described by parabolic band models, a quadratic  $A_{\text{em}}^2$  term whose strength is related to the system's Drude weight [22] and *f*-sum rule [23] also emerges naturally from minimal coupling. It has long been understood [24] that the Dicke model's SPT is suppressed when the quadratic terms are retained. Demonstrations of this property are often referred to as *no-go* theorems. (Standard *no-go* theorems do not apply [25] to ultracold atoms which are driven by an external pump field and subject to significant cavity losses.) Electronic states near the neutrality point of a graphene sheet are described at low energies by a 2D massless Dirac fermion (MDF) Hamiltonian [1], which is *linear* in momentum  $p$ . One of the twists offered by the Dicke model of graphene cavity QED is therefore the following [26]: minimal coupling applied to the MDF Hamiltonian does *not* generate a term proportional to  $A_{\text{em}}^2$ . Cyclotron resonance in this material, which has been extensively investigated experimentally and theoretically over the past decade [27], seems therefore to provide an example of an active medium which could enable a SPT [26] when the graphene sheet is embedded in a cavity. In this work we demonstrate, however, that in the strong coupling regime the Dicke model for graphene cavity cyclotron resonance must be supplemented by a quadratic term that is dynamically generated by interband transitions and again implies a *no-go* theorem.

**Gauge invariance and SPTs.**—We consider an electronic system in  $D$  spatial dimensions coupled to an

electromagnetic (em) field with a single privileged mode described by a vector potential  $\mathbf{A}(\mathbf{r}, t)$ . We argue below that the no-go theorem for the SPT requires only unbroken gauge symmetry. Our ideas are most clearly spelled out when  $\mathbf{A}$  is treated classically. Quantization of the em field can be easily carried out in the final step. Light-matter interactions are described by minimal coupling:  $\mathbf{p}_i \rightarrow \mathbf{p}_i + e\mathbf{A}(\mathbf{r}_i, t)/c$ , where  $\mathbf{p}_i$  is the canonical momentum of the  $i$ th electron and  $-e$  is the electron charge. The Hamiltonian of a light-matter system can always be written as  $\hat{\mathcal{H}}[\mathbf{A}] = \hat{\mathcal{H}}_{\text{mat}}[\mathbf{A}] + \mathcal{H}_{\text{em}}[\mathbf{A}]$ , where  $\hat{\mathcal{H}}_{\text{mat}}[\mathbf{A}]$  contains all the electronic degrees of freedom treated quantum mechanically, while  $\mathcal{H}_{\text{em}}[\mathbf{A}]$  is the classical energy density of the em field. The spontaneous coherent photon state is the ground state when the total energy is lowered by introducing a finite static vector potential. Since  $\mathcal{H}_{\text{em}}[\mathbf{A}]$  is a positive-definite quadratic form of  $\mathbf{A}$ , the instability can occur only if the second derivative of the matter energy with respect to  $\mathbf{A}$  is negative for static  $\mathbf{A}$ .

We therefore consider the variation of the matter energy  $\Delta E_{\text{mat}} \equiv E_{\text{mat}}[\delta\mathbf{A}] - E_{\text{mat}}[0]$  due to an infinitesimal variation of the static vector potential:

$$\Delta E_{\text{mat}} = \int d^D\mathbf{r} \delta\mathbf{A} \cdot \langle \delta\hat{\mathcal{H}}_{\text{mat}}[\mathbf{A}]/\delta\mathbf{A} \rangle. \quad (1)$$

The quantity  $\delta\hat{\mathcal{H}}_{\text{mat}}[\mathbf{A}]/\delta\mathbf{A}$  is [28] the physical current operator,  $\hat{\mathbf{J}}_{\text{phys}}(\mathbf{r})$ . It is convenient to

The Hamiltonian which describes coupling between MDFs and light in the cavity does not contain a quadratic term:  $\mathcal{H}_{\text{int}} = v_D(e/c)\boldsymbol{\sigma} \cdot \mathbf{A}_{\text{em}}(\mathbf{r})$ . For future purposes we introduce the notations  $\sigma^\pm = (\sigma^x \pm i\sigma^y)/2$  and  $A_{\text{em}}^\pm(\mathbf{r}) = A_{\text{em}}^x(\mathbf{r}) \pm iA_{\text{em}}^y(\mathbf{r})$ . In what follows we neglect [26] the spatial variation of the em field in the cavity,  $A_{\text{em}}^\pm(\mathbf{r}) \rightarrow A_{\text{em}}^\pm$ , since the photon wavelength is normally much larger than other length scales in the problem. In this quasiniform approximation we can easily evaluate the matrix elements of  $\mathcal{H}_{\text{int}}$  between the unperturbed pseudospinors (4):

$$\langle \lambda', n', k' | \mathcal{H}_{\text{int}} | \lambda, n, k \rangle = \frac{ev_D}{c} \delta_{k,k'} (\lambda C_{n'}^- C_n^+ \delta_{n',n+1} A_{\text{em}}^- + \lambda' C_{n'}^+ C_n^- \delta_{n',n-1} A_{\text{em}}^+). \quad (5)$$

The strong coupling limit is most easily obtained when the Fermi energy  $\varepsilon_F$  lies within one of the bands; we consider the case in which it lies in the conduction band ( $\lambda = +1$ ) between the LL with index  $n = M$ , which is fully occupied, and the LL with index  $n = M + 1$ , which is at least partially empty. (See Fig. 1.) The Dicke model of cavity cyclotron resonance includes only the intraband  $n = M$  to  $n = M + 1$  transition and acts in the  $2^{\mathcal{N}}$ -fold subspace spanned by  $\{|+, M, k\rangle, |+, M + 1, k\rangle, k = 1, \dots, \mathcal{N}\}$ , neglecting interband transitions [26]. Using Eq. (5) and

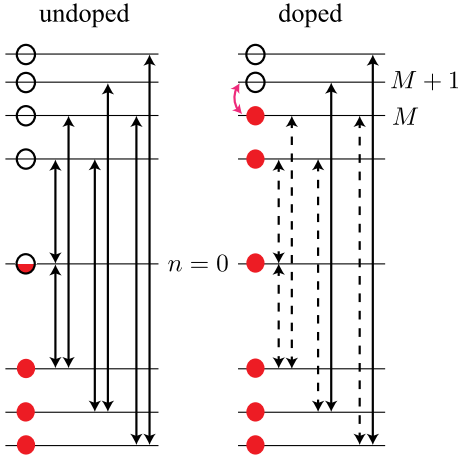

FIG. 1 (color online). Left-hand panel: Dipole allowed transitions in a neutral graphene sheet in the presence of an external magnetic field. The horizontal lines denote the unevenly spaced Landau levels of massless Dirac fermions. The filled valence band levels ( $\lambda = -1$ ) and the empty conduction band levels ( $\lambda = +1$ ) are indicated by filled (empty) circles. The zero-energy ( $n = 0$ ) Landau level is formed partly from the valence band and partly from the conduction band and is half filled in a neutral system. Right-hand panel: In a doped graphene sheet with a Fermi level  $\varepsilon_F$  placed between the conduction band  $n = M$  and the  $n = M + 1$  Landau levels, there is an allowed cyclotron transition within the conduction band (magenta arrow) while some of the lower energy interband transitions, indicated by dashed lines, are Pauli blocked. There is a clear energetic separation between the lowest energy (unblocked) intraband transition and the (unblocked) interband transitions.

introducing a set of Pauli matrices  $\{\mathbb{1}_k, \tau_k^z, \tau_k^\pm, k = 1, \dots, \mathcal{N}\}$  which act in this two-level-system subspace leads to the following pseudospin Hamiltonian:

$$\mathcal{H}_{\text{eff}} = \sum_{k=1}^{\mathcal{N}} \left( \mathcal{E}_M \mathbb{1}_k - \frac{\Omega_M}{2} \tau_k^z + \epsilon_{\text{em}} \tau_k^+ + \epsilon_{\text{em}}^* \tau_k^- \right), \quad (6)$$

where  $\mathcal{E}_M = \hbar\omega_c(\sqrt{M} + \sqrt{M+1})/2$ ,  $\Omega_M = \hbar\omega_c(\sqrt{M+1} - \sqrt{M})$ , and  $\epsilon_{\text{em}} = ev_D A_{\text{em}}^- / (2c)$ . In this model the occupied conduction-band LL shifts down in energy by

$$\Delta E_M^{(\text{intra})} = -\mathcal{N} \left( \frac{ev_D}{2c} \right)^2 \frac{A_{\text{em}}^2}{\hbar\omega_c} (\sqrt{M+1} + \sqrt{M}) \quad (7)$$

in the limit of a static vector potential, in violation of gauge invariance, as explained in the previous section. This is the origin of the SPT found in Ref. [26]. The correct effective matter Hamiltonian  $\mathcal{H}_{\text{mat}}$  for graphene cavity cyclotron resonance must repair this defect.

The Dicke model misses a diamagnetic contribution to  $\mathcal{H}_{\text{mat}}$ , which, according to (3), must precisely cancel the spurious energy shift (7). To derive this term we first recognize the intrinsic two-band nature of graphene (see Fig. 1). A generic valence band state  $|-, n, k\rangle$  is coupled by the em field to two states in conduction band:  $|+, n + 1, k\rangle$  and  $|+, n - 1, k\rangle$ . We first consider the undoped limit in which all valence band states  $|-, n, k\rangle$  are occupied. Because the Dirac model applies over a large but finite energy region, we must apply a cutoff by occupying valence band levels with  $0 \leq n \leq \nu_{\text{max}}$ . Treating the em field again by second-order perturbation theory, we find the following change in matter energy for an undoped graphene sheet in a quantizing magnetic field:

$$\Delta E_{\text{undoped}} = \sum_{k=1}^{\mathcal{N}} \sum_{n=0}^{\nu_{\text{max}}} \left[ p_n \frac{|\langle +, n + 1, k | \mathcal{H}_{\text{int}} | -, n, k \rangle|^2}{\varepsilon_{-,n}^{(0)} - \varepsilon_{+,n+1}^{(0)}} + p_{n-1} \frac{|\langle +, n - 1, k | \mathcal{H}_{\text{int}} | -, n, k \rangle|^2}{\varepsilon_{-,n}^{(0)} - \varepsilon_{+,n-1}^{(0)}} \right], \quad (8)$$

where  $p_n = 1 - \delta_{n,0}/2$ . (The factor  $p_n$  takes care of transitions involving the  $n = 0$  LL, which is half filled.) Using Eq. (5) for the matrix elements, we can write Eq. (8) more explicitly:

$$\Delta E_{\text{undoped}} = -\mathcal{N} \left( \frac{ev_D}{2c} \right)^2 \frac{A_{\text{em}}^2}{\hbar\omega_c} [1 + F(\nu_{\text{max}})], \quad (9)$$

with  $F(\nu) \equiv \sum_{n=1}^{\nu} \left( \frac{1}{\sqrt{n} + \sqrt{n+1}} + \frac{1}{\sqrt{n} + \sqrt{n-1}} \right)$ . Once again, this large negative contribution to the change in matter energy is spurious. It is present because the Dirac model with a rigid ultraviolet cutoff  $\nu_{\text{max}}$  breaks gauge invariance [31]. When a model that is correct at atomic length scales, for example, a  $\pi$ -band tight-binding model, is used instead, a static vector potential merely reassigns momentum labels within the full valence band. We compensate exactly for this deficiency of the Dirac model at its ultraviolet cutoff

scale by adding the positive quantity  $-\Delta E_{\text{undoped}}$  to the change in matter energy.

We now reconsider the situation analyzed earlier in which the Fermi energy  $\varepsilon_F$  lies in conduction band ( $\lambda = +1$ ) between LLs with indices  $n = M$  and  $n = M + 1$ , but account for interband transitions. The *interband* correction to the energy shift  $\Delta E_M^{(\text{intra})}$  in Eq. (7) can be calculated using an expression which is equivalent to Eq. (8) but accounts for *Pauli blocking* of transitions to occupied conduction-band states. The final result for the interband contribution is given by

$$\begin{aligned} \Delta E_M^{(\text{inter})} &= -\Delta E_{\text{undoped}} - \mathcal{N} \left( \frac{ev_D}{2c} \right)^2 \frac{A_{\text{em}}^2}{\hbar\omega_c} \\ &\quad \times [F(\nu_{\text{max}}) - F(M)] \\ &= \mathcal{N} \left( \frac{ev_D}{2c} \right)^2 \frac{A_{\text{em}}^2}{\hbar\omega_c} [1 + F(M)], \end{aligned} \quad (10)$$

where the term  $-\Delta E_{\text{undoped}}$  takes care of the Dirac model regularization and Eq. (9) has been used in the last equality. After noticing that  $1 + F(M) = \sqrt{M+1} + \sqrt{M}$ , we finally obtain

$$\Delta E_M^{(\text{inter})} = \mathcal{N} \left( \frac{ev_D}{2c} \right)^2 \frac{A_{\text{em}}^2}{\hbar\omega_c} (\sqrt{M+1} + \sqrt{M}). \quad (11)$$

The quantity  $\Delta E_M^{(\text{inter})}$  is a dynamically generated interband diamagnetic contribution to the effective Hamiltonian  $\mathcal{H}_{\text{eff}}$ , which (i) is independent of the cutoff  $\nu_{\text{max}}$  and (ii) satisfies  $\Delta E_{\text{mat}} = \Delta E_M^{(\text{intra})} + \Delta E_M^{(\text{inter})} = 0$ ; i.e., in the limit of a static vector potential, it precisely cancels the spurious shift (7) responsible for the Dicke model SPT.

Because intraband transition energies are much lower than interband transitions in the weak-field limit relevant to the strong coupling limit of cavity cyclotron resonance, we can neglect the frequency dependence of the dynamically generated quadratic term. This energy must be added to the effective matter Hamiltonian (6) for graphene cavity cyclotron resonance:

$$\mathcal{H}_{\text{eff}} \rightarrow \mathcal{H}_{\text{eff}} + S \frac{\mathcal{D}_M}{2\pi c^2} A_{\text{em}}^2, \quad (12)$$

where  $\mathcal{D}_M = 4\mathcal{E}_M\sigma_{\text{uni}}/\hbar$  is the Drude weight [29,31] expressed in terms of the function  $\mathcal{E}_M$  introduced right after Eq. (6). This Hamiltonian is the starting point of the cavity QED theory of graphene cyclotron resonance. The  $A_{\text{em}}^2$  quadratic supplement to the Dicke model is always critical in the strong coupling limit. Equation (12) is the most important result of this work.

*Quantum theory.*—We can quantize the em field by promoting the positive and negative Fourier amplitudes of  $A_{\text{em}}$  to photon annihilation  $a$  and creation  $a^\dagger$  operators:  $A_{\text{em}} = \mathcal{A}\boldsymbol{\epsilon}(a + a^\dagger)$ , where  $\boldsymbol{\epsilon}$  is a unit vector describing the polarization of the em field and  $\mathcal{A} = \sqrt{2\pi\hbar c^2/(\varepsilon\omega V)}$ , with  $V = SL_z$  the volume of the cavity ( $L_z \ll L$  is the height of the cavity in the direction perpendicular to

graphene) and  $\varepsilon$  its dielectric constant. When a cavity mode with frequency  $\omega$  is nearly resonant with the cyclotron transition frequency  $\Omega_M$ , the total Hamiltonian (12) yields a Dicke model supplemented by an  $A_{\text{em}}^2$  term:

$$\begin{aligned} \mathcal{H}_{\text{Dicke}} &= \hbar\omega a^\dagger a - \frac{\Omega_M}{2} \sum_{k=1}^{\mathcal{N}} \tau_k^z + \frac{g}{\sqrt{\mathcal{N}}} \sum_{k=1}^{\mathcal{N}} \tau_k^x (a + a^\dagger) \\ &\quad + \kappa (a + a^\dagger)^2, \end{aligned} \quad (13)$$

where  $g = \hbar\omega_c\sqrt{2\sigma_{\text{uni}}/(\varepsilon\omega L_z)}$  and  $\kappa = \hbar\mathcal{D}_M/(\varepsilon\omega L_z)$ . In writing Eq. (13) we have assumed a specific polarization of the em field; i.e.,  $\boldsymbol{\epsilon} = \hat{x}$ . In the thermodynamic  $\mathcal{N} \rightarrow \infty$  limit the model (13) undergoes a SPT if the condition  $\omega\Omega_M(1 + 4\kappa/\omega)/(4g^2) < 1$  is satisfied [16,24]. In our case, however, a SPT is forbidden because the following identity holds true:

$$g^2 = \kappa\Omega_M, \quad (14)$$

which specifically establishes a no-go theorem for the occurrence of a SPT in the graphene cyclotron resonance cavity QED. It is not a coincidence, and instead follows directly from the cancellation between paramagnetic and diamagnetic currents discussed in the first part of this work. The paramagnetic response of the Hamiltonian (13) to a static and quasihomogeneous em field is, indeed,  $(g^2/\mathcal{N})\lim_{\omega \rightarrow 0} \langle\langle \tau_{\text{tot}}^x; \tau_{\text{tot}}^x \rangle\rangle_\omega = -2g^2/\Omega_M$ , where  $\tau_{\text{tot}}^x = \sum_k \tau_k^x$  and  $\langle\langle \tau_{\text{tot}}^x; \tau_{\text{tot}}^x \rangle\rangle_\omega = 2\mathcal{N}\Omega_M/(\omega^2 - \Omega_M^2)$  [32]. According to Eq. (3), this paramagnetic contribution must be equal in magnitude and opposite in sign to the diamagnetic response of (13), which is simply  $2\kappa$ ; i.e., it must satisfy  $\kappa = g^2/\Omega_M$ , which coincides with Eq. (14).

*Summary and discussion.*—We have derived a microscopic effective Hamiltonian—Eq. (12)—for graphene cavity cyclotron resonance, highlighting, in particular, the role of gauge invariance and Drude weight. From the point of view of graphene fundamental physics and quantum optics, Eq. (12) is a key result that can be used to address a number of subtle issues. First of all, it goes without saying that Eq. (12) is the proper theoretical tool to analyze graphene cavity cyclotron resonance physics which, even in the absence of superradiant phases, retains all its appeal due to the gate tunability and versatility of the active material [2–7,9]. Useful applications of Eq. (12) can also be foreseen in studies of the poorly understood [27] electron-electron interaction corrections to cyclotron resonance transition energies in graphene and other Dirac materials. Finally, it is worth mentioning that our work does not touch upon the interesting possibility of realizing superradiant phases when massless Dirac fermions are driven away from equilibrium.

We thank R. Fazio for fruitful discussions. This work was supported by MIUR-FIRB Grants No. RBID08B3FM and No. RBFR10M5BT, Welch Foundation Grant No. TBF1473, and by DOE Division of Materials Sciences and Engineering Grant No. DE-FG03-02ER45958.

\*Corresponding author.

m.polini@sns.it

- [1] M. I. Katsnelson, *Graphene: Carbon in Two Dimensions* (Cambridge University Press, Cambridge, England, 2012).
- [2] F. Bonaccorso, Z. Sun, T. Hasan, and A. C. Ferrari, *Nat. Photonics* **4**, 611 (2010).
- [3] N. M. R. Peres, *Rev. Mod. Phys.* **82**, 2673 (2010).
- [4] F. H. L. Koppens, D. E. Chang, and F. J. García de Abajo, *Nano Lett.* **11**, 3370 (2011).
- [5] A. N. Grigorenko, M. Polini, and K. S. Novoselov, *Nat. Photonics* **6**, 749 (2012).
- [6] M. Engel, M. Steiner, A. Lombardo, A. C. Ferrari, H. v. Loehneysen, P. Avouris, and R. Krupke, *Nat. Commun.* **3**, 906 (2012).
- [7] M. Furchi, A. Urich, A. Pospischil, G. Lilley, K. Unterrainer, H. Detz, P. Klang, A. M. Andrews, W. Schrenk, G. Strasser, and T. Mueller, *Nano Lett.* **12**, 2773 (2012).
- [8] J. M. Raimond, M. Brune, and S. Haroche, *Rev. Mod. Phys.* **73**, 565 (2001); H. Mabuchi and A. C. Doherty, *Science* **298**, 1372 (2002); H. Walther, B. T. H. Varcoe, B.-G. Englert, and T. Becker, *Rep. Prog. Phys.* **69**, 1325 (2006).
- [9] K. S. Novoselov, *Rev. Mod. Phys.* **83**, 837 (2011).
- [10] K. S. Novoselov, D. Jiang, F. Schedin, T. J. Booth, V. V. Khotkevich, S. V. Morozov, and A. K. Geim, *Proc. Natl. Acad. Sci. U.S.A.* **102**, 10451 (2005).
- [11] R. H. Dicke, *Phys. Rev.* **93**, 99 (1954).
- [12] K. Hepp and E. H. Lieb, *Ann. Phys. (N.Y.)* **76**, 360 (1973); Y. K. Wang and F. T. Hioe, *Phys. Rev. A* **7**, 831 (1973); K. Hepp and E. H. Lieb, *ibid.* **8**, 2517 (1973).
- [13] For a recent review on circuit QED, see, e.g., M. Devoret, S. Girvin, and R. Schoelkopf, *Ann. Phys. (Amsterdam)* **16**, 767 (2007).
- [14] P. Nataf and C. Ciuti, *Phys. Rev. Lett.* **104**, 023601 (2010).
- [15] P. Nataf and C. Ciuti, *Nat. Commun.* **1**, 72 (2010).
- [16] O. Viehmann, J. von Delft, and F. Marquardt, *Phys. Rev. Lett.* **107**, 113602 (2011).
- [17] F. Brennecke, T. Donner, S. Ritter, T. Bourdel, M. Köhl, and T. Esslinger, *Nature (London)* **450**, 268 (2007).
- [18] K. Baumann, C. Guerlin, F. Brennecke, and T. Esslinger, *Nature (London)* **464**, 1301 (2010).
- [19] D. Hagenmüller, S. De Liberato, and C. Ciuti, *Phys. Rev. B* **81**, 235303 (2010).
- [20] G. Scalari, C. Maissen, D. Turčinková, D. Hagenmüller, S. De Liberato, C. Ciuti, C. Reichl, D. Schuh, W. Wegscheider, M. Beck, and J. Faist, *Science* **335**, 1323 (2012).
- [21] In the ultrastrong limit the strength of the radiation-induced coupling between two consecutive LLs is of the same order as the bare cyclotron transition energy.
- [22] D. Pines and P. Nozières, *Theory of Quantum Liquids* (W. A. Benjamin, Inc., New York, 1966).
- [23] G. F. Giuliani and G. Vignale, *Quantum Theory of the Electron Liquid* (Cambridge University Press, Cambridge, England, 2005).
- [24] K. Rzażewski, K. Wódkiewicz, and W. Żakowicz, *Phys. Rev. Lett.* **35**, 432 (1975); I. Białynicki-Birula and K. Rzażewski, *Phys. Rev. A* **19**, 301 (1979); K. Gawędzki and K. Rzażewski, *ibid.* **23**, 2134 (1981).
- [25] J. Keeling, M. J. Bhaseen, and B. D. Simons, *Phys. Rev. Lett.* **105**, 043001 (2010); V. M. Bastidas, C. Emary, B. Regler, and T. Brandes, *ibid.* **108**, 043003 (2012).
- [26] D. Hagenmüller and C. Ciuti, preceding Letter, *Phys. Rev. Lett.* **109**, 267403 (2012).
- [27] See, e.g., M. O. Goerbig, *Rev. Mod. Phys.* **83**, 1193 (2011).
- [28] Strictly speaking, this derivative yields the current operator Fourier component with wave vector  $\mathbf{q}$  equal to the lateral wave vector of the privileged photon mode. In practice,  $\mathbf{q} = \mathbf{0}$ .
- [29] See Supplemental Material at <http://link.aps.org/supplemental/10.1103/PhysRevLett.109.267404> for more technical details with respect to those contained in the main text on the connection between gauge invariance and super-radiant phase transitions.
- [30] Although it is clear that the gauge invariance condition (3) is valid in the presence of electron-electron interactions, for simplicity, in this section we restrict the analysis to a noninteracting gas of MDFs. At equilibrium, the impact of electron-electron interactions on the graphene cavity cyclotron resonance theory is merely quantitative.
- [31] S. H. Abedinpour, G. Vignale, A. Principi, M. Polini, W.-K. Tse, and A. H. MacDonald, *Phys. Rev. B* **84**, 045429 (2011).
- [32] See, e.g., S. H. Abedinpour, M. Polini, A. H. MacDonald, B. Tanatar, M. P. Tosi, and G. Vignale, *Phys. Rev. Lett.* **99**, 206802 (2007).